

DOOR SECURITY

A GUIDE TO SECURITY DOORSETS AND ASSOCIATED LOCKING HARDWARE

June 2013

This guide has been prepared by BRE Global in partnership with the Centre for the Protection of National Infrastructure (CPNI) with input from the Home Office's Centre for Applied Science and Technology (CAST). It is intended to help security managers and practitioners working for the UK Government and critical national infrastructure to specify the design and installation of security hinged doorsets, and their associated locking hardware.

Contents

Executive summary	
Where to find more information	5
Introduction	6
Threats	7
Requirements	7
Operational requirements	7
Statutory requirements	8
Doorsets	9
Features of a doorset and their effect on a doorset’s resistance to forced entry	12
Introduction	12
Door leaf	13
Door frame	15
Hardware	15
Other features	16
Vision panels	16
Door viewers (spy glasses).....	18
Ventilation panels	18
Side and overhead panels.....	18
Door hardware	19
Locking hardware	19
Lock position	20
Number and layout of bolts	20
Auto-bolting	21
Auto-deadlocking.....	21
External lock operation.....	22
Cylinders and cylinder guards	22
Internal lock operation	24
Locks for Automatic Access Control Systems	25
Modular locking systems	29
Padlocks	29
Hinges	31

Dog bolts **32**
Doorset installation and maintenance **34**
Forcible entry performance standards **35**
Physical Barriers Attack Standard (PBAS) **35**
References..... **41**

Appendices

A Additional guidance on general doorset design and performance 42
B Doorset and lock performance standards 50
C Third party certification 56
D Alternative methods of lock operation 57
E Glossary 59

Executive summary

The aim of this guide is to familiarise the reader with important features of security hinged^a doorsets designed to prevent forced entry into buildings or protected areas within buildings. For guidance on doorsets providing protection against undetected compromise, please contact CPNI: www.cpni.gov.uk/contact-us.

How a doorset is configured can affect its resistance to forced entry as much as the selection of the materials used to construct it. The following figure illustrates the relative effect that different features of a doorsets' construction can have on its resistance to forced entry.

Table 1 Relationship between a doorset's design and its resistance to forced entry

Resistance	Mode of Opening	Number of Leaves	Leaf	Bolting Points	Bolt Engagement	Dead-lockable Operation	Vision Panels
More secure	Outward	Single	Solid	Multi-point deadbolt	Small gap between frame and door and good bolt throw	Deadlock by key on inside only (single cylinder on inside only)	None
↑	Inward		Framed or Panelled	Single point deadbolt		Non-lockable (thumb turn)	Laminated security glass containing polycarbonate
							Laminated security glass containing PVB interlayers
Less secure	Bi-directional	Double	Unframed	Single point latch bolt	Large gap and minimal bolt throw	Non-lockable (lever handle)	Toughened or wired glass

Other aspects of a doorset's construction which can affect its resistance to forced entry include:

- the thickness of the door leaf
- frame profile (thickness and depth of rebate)
- quantity and quality of hinges
- quantity and design of dog bolts
- profile of meeting stiles on double leaf doorsets
- presence of additional locking devices
- protection of locking devices (drill resistant plates, security escutcheons and cylinder guards)
- the method by which the doorset is assembled and installed.

^a This guide does not cover other types of doorset such as cantilever, folding, revolving, rolling or sliding doorsets. For further guidance on those types of doorset, please contact your CPNI adviser.

CPNI uses two separate classification systems to indicate a doorsets' resistance to attack according to the nature of the threat:

- doorsets that provide resistance to asset theft and asset damage are attributed a CPNI Protection Level (i.e. BASE, ENHANCED or HIGH); and
- doorsets which prevent undetected compromise of an asset are attributed a CPNI CLASS rating (i.e. 1, 2, 3 or 4).

Prior to 2009, doorsets which had been evaluated to determine their resistance to forced entry were attributed SEAP Class ratings. The term SEAP is no longer used and has been replaced by CPNI, which is trademarked.

Where to find more information

- Each site will generally have its own specific issues which must be addressed. The relevant CPNI sector adviser should be contacted for specialist advice. Contact can also be made with CPNI via www.cpni.gov.uk/contact-us.
- Those protecting Government Protectively Marked Material (PMM) should consult the Security Policy Framework (SPF)¹.
- Defence users should abide by the requirements contained in the Defence Manual of Security (JSP440).
- In addition, consideration may be given to using doorsets which have been approved by the Loss Prevention Certification Board (LPCB) to LPS 1175: Issue 72. These products are listed in the Red Book, www.redbooklive.com. However, it is important to ensure that such products are fully suitable for use at the locations where they are required. Contact the relevant CPNI sector adviser for further advice.
- Further information regarding other standards is provided in the section *Forcible entry performance standards*.

Introduction

Security doorsets form part of an integrated site security system. It is important that their performance is considered in conjunction with other aspects of site security such as CCTV, detection systems, manned guarding and security procedures. For further guidance contact CPNI.

Where necessary, security doorsets and their associated locking hardware should:

- delay intruders attempting to penetrate the doorset in order to enter the protected building/area (resistance to forced entry);
- at minimum, resist the creation of a full-body access aperture through the fabric of the leaf. This aperture is defined in CPNI's *Physical Barrier Attack Standard (PBAS)* and LPS 1175, through which an elliptical test block measuring 400 mm (major radius) by 225 mm (minor radius) may be passed;
- prevent undetected entry into the protected area (resistance to undetected compromise^b);
- allow safe egress from the protected building/area in an emergency while preventing unauthorised entry;
- comply with relevant Building Regulations; e.g. those relating to fire, safety under impact and mobility;
- be suitably durable and maintainable;
- be securely installed within compatible structures. This is because a security doorset installed into a weaker 'incompatible' structure may:
 - fail to prevent unauthorised entry. For example, it may be possible for an intruder to remove the doorset from the surrounding structure or penetrate the surrounding structure in order to operate door release mechanisms located on the protected side of the doorset;
 - lead to structural damage. For example, if a doorset incorporating a heavy door leaf is fitted within a lightweight partition, the surrounding partition may crack due to door leaf opening and closing repeatedly causing fatigue fractures of the walling material. In some cases, the fixings holding the doorset within the wall may also fail.

In some cases it may be impractical to source a doorset that not only delivers the level of security required but which also delivers the other functionality and performance (e.g. fire resistance, acoustics) sought. In such instances, consideration should be given to using pairs of doors forming a lobby. The lobby could consist of the following configurations:

- one doorset, preferably the inner door (second doorset) in the configuration, would achieve the security level sought; or
- both doorsets would collectively provide the required level of resistance to forced entry.

^b For further guidance regarding protection against undetected compromise, please contact CPNI: www.cpni.gov.uk/contact-us

Threats

It is important to ensure that doorsets and their associated locking hardware are suitable for the environment in which they are to be used and the threats posed. Such threats may include:

- accidental damage
- espionage
- fire
- natural phenomena (e.g. flood, high winds, corrosive atmospheres)
- opportunistic crime
- organised crime
- protestors
- terrorism
- vandalism
- use (e.g. wear and tear)

The severity of the threat will depend on the nature of the site on which they are located, their location on the site, and other protective measures employed there.

Further guidance on issues affecting the selection and use of doorsets and their associated locking hardware, such as fire safety and accessibility, is provided in Appendix B.

Requirements

Operational requirements

A well-defined operational requirement is essential when procuring effective doorsets and associated locking hardware. It is therefore recommended^c that an Operational Requirement (OR) is prepared before selecting any products.

An Operational Requirement (OR) is a statement of needs based upon a thorough and systematic assessment of the problem to be solved and the desired solutions.

The OR should be specific to each location and be based on an understanding of the threats and how they can be mitigated. High level requirements for the site should be captured within the Level 1 OR, whilst the more detailed Level 2 OR should consider the following sections of this guide at a minimum.

The requirements may be prescriptive (e.g. ‘the doorset must be timber’) or performance based (e.g. ‘the doorset must resist attempts at forced entry conducted by a defined number of intruders of a certain skill and knowledge using a defined set of tools, for a defined time’). It is recommended that the OR is, as far as possible, performance based. Where prescriptive requirements are defined, it is important that they do not conflict with other requirements.

^c Those working within Government must produce an OR. It is a mandatory requirement of the Cabinet Office – Security Policy Framework (SPF).

Further [guidance](#) on producing operational requirements is available to download from CPNI's public website www.cpni.gov.uk.

Statutory requirements

In the UK, installation and use of security doorsets and their associated hardware is covered by the following statutory requirements:

The Occupiers Liability Acts

Disability/Equality Discrimination Act

Construction Products Regulations 1991: These were implemented in the UK in response to the EU Construction Products Directive (89/106/EEC) covering CE marking of construction products. The regulations define rules governing products used in construction, and seek to remove technical barriers to the trade of construction products.

The Building Act 1984: This is the primary legislation under which the Building Regulations and other secondary legislation are made. The building regulations particularly relevant to doorsets and their associated locking hardware are:

- **Approved Document B:** Fire safety. This section covers the technical guidance contained in Part B of schedule 1 of the Building Regulations, which is concerned with the requirements with respect to fire safety.
- **Approved Document K:** Protection from falling, collision and impact.
- **Approved Documents L2A and L2B:** Conservation of fuel and power in new buildings other than dwellings (L2A) and existing buildings other than dwellings (L2B).
- **Approved Document M:** Access to and use of buildings.
- **Approved Document N:** Glazing – Safety in relation to impact, opening and cleaning.

The Sustainable and Secure Buildings Act 2004: This introduced new powers and requirements with respect to a range of building related issues, including:

- sustainability
- Crown buildings
- security
- historic buildings
- removal of exemptions
- report on the building stock
- local authority registers of information
- enforcement measures

However, not all sections of the Sustainable and Secure Buildings Act were enacted at the time this document was published, and some of them would require new regulations to give them effect.

The requirements contained within these documents must be taken into account when specifying a doorset and associated locking hardware.

Doorsets

This guide relates specifically to security hinged doorsets. Other main types of doorset not covered in this guide are:

Cantilever: These are typically used on garages and are often referred to as 'up-and-over' doorsets.

Folding: These are formed from a series of vertical leaves with hinged joints. The leaves fold together (concertina) as the door is opened. They are commonly referred to as 'concertina doorsets'.

Revolving: These are formed from a number of leaves attached to a centre pivot. They are commonly used on tall buildings to control the flow of air into and out of the building when people pass through.

Rolling: These are otherwise commonly referred to as 'roller' or 'rolling shutters'. They are formed from a series of laths joined together to form a curtain which is hung on a roller. The two sides of the curtain are mounted in guides. Rolling doorsets are generally not designed for use on pedestrian routes, but may be used to provide supplementary protection for primary entrance doors during periods when the property is vacant.

Sectional overhead: Like rolling doorsets, these are not designed for use on pedestrian routes. They are generally formed from a series of horizontal insulated panels which are hinged together, one above the other. The ends of the panels run in tracks such that the panels initially lift vertically and then once clear of the aperture, travel horizontally. Their primary use is on large scale goods entrances, which require better levels of thermal and sound insulation than is possible using rolling doorsets.

Sliding: These may be formed from one or more leaves which slide open and closed in a horizontal direction. They are commonly used on entrances with high flows of pedestrian traffic, such as office buildings and shops.

Figure 1 *Alternative door types*

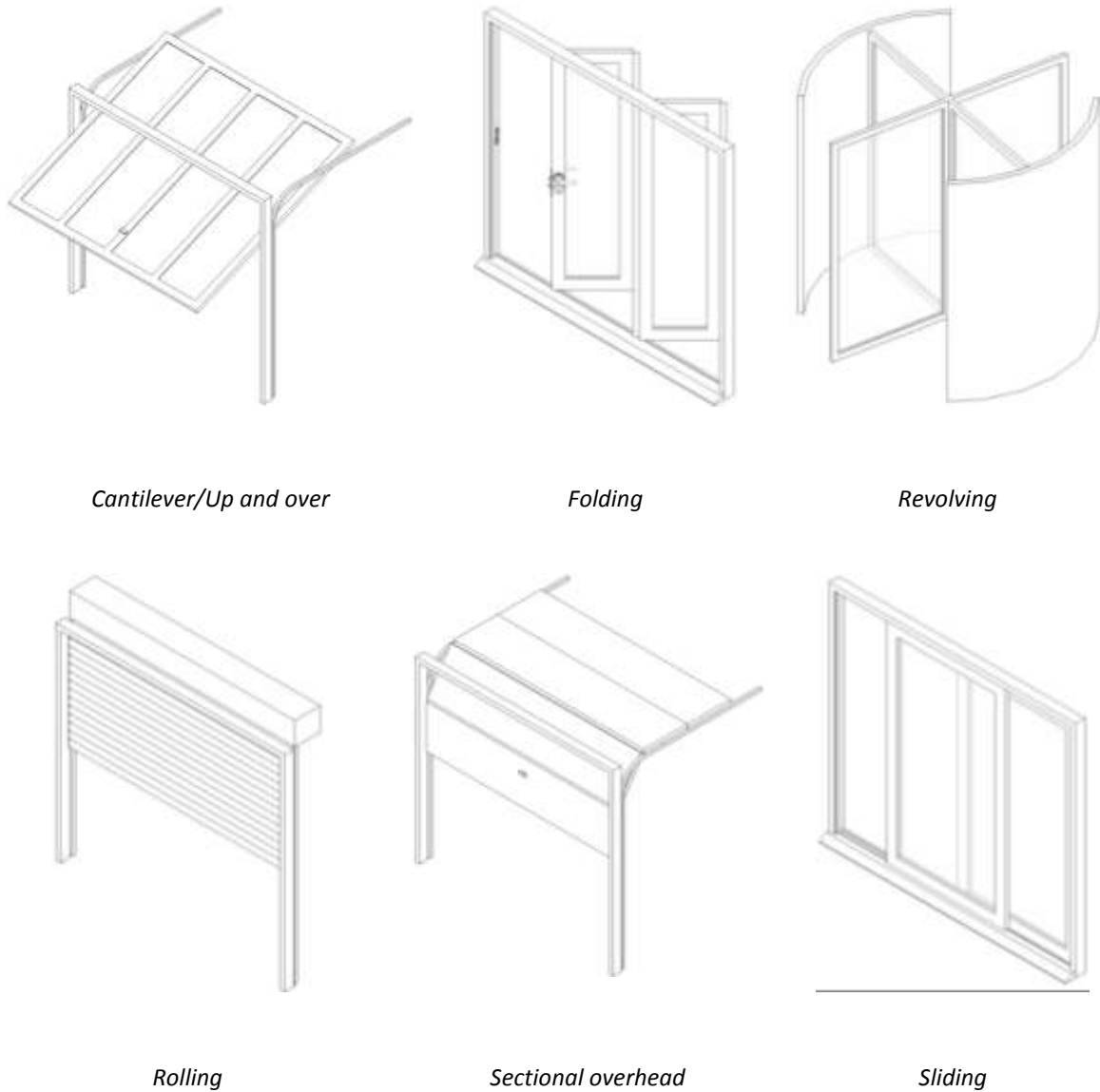

A hinged doorset comprises a number of elements, as illustrated in the executive summary.

Security doorsets are generally assembled by the manufacturer prior to delivery on site. However, in some instances (particularly those doorsets designed for domestic situations or other locations with restricted access to the doorway during installation) the doorsets may be supplied as a kit of parts which are assembled on site. These are typically known as 'door assemblies'.

Wherever possible, doorsets should be specified rather than door assemblies. This is because the latter is rarely supported by evidence of the combined door assembly's conformity with the appropriate performance requirements.

Specifying doorsets also has other advantages:

- Doorsets can be installed much later in the build programme, especially if they are of a cassette design that slots into a pre-formed aperture. This reduces the opportunity for damage to occur to the door between its installation and the building being completed and handed over.
- Doorsets require far less assembly of components on site.

Doorsets may be formed from a wide range of materials. The most common materials used are listed in their approximate relative order of resistance to forced entry with the most resistant first:

- fabricated steel
- solid timber
- steel extrusions
- aluminium extrusions
- PVCu
- glazed timber, aluminium or steel^d
- glass^e

It is important to ensure that the materials and finishes specified do not adversely affect the doorset's ability to deliver the required performance, and that they are:

- widely available and, wherever possible, will remain so over the lifetime of the product;
- available from sustainable sources and can be recycled at the end of the product's life;
- not hazardous and are not on the lists of banned materials available from the European Commission's Enterprise and Industry website - ec.europa.eu/enterprise - or the Health and Safety Executive - www.hse.gov.uk - websites;
- economically viable to use and maintain.

Doorsets should be designed to deliver appropriate levels of durability, according to the envisaged frequency of use the doorset is expected to be exposed to. Further guidance on durability standards is provided in Appendix B.

Doorsets and their associated hardware should incorporate adequate means to prevent casual dismantling or tampering.

^d This refers to timber, aluminium and steel doorsets containing large areas of glazing.

^e This refers to 'fully glazed' doors.

Features of a doorset and their effect on a doorset's resistance to forced entry

Introduction

The features of a doorset are illustrated in Figure 2, while their influence on a doorset's resistance to forced entry is discussed in the following sections.

Figure 2 Features of a doorset

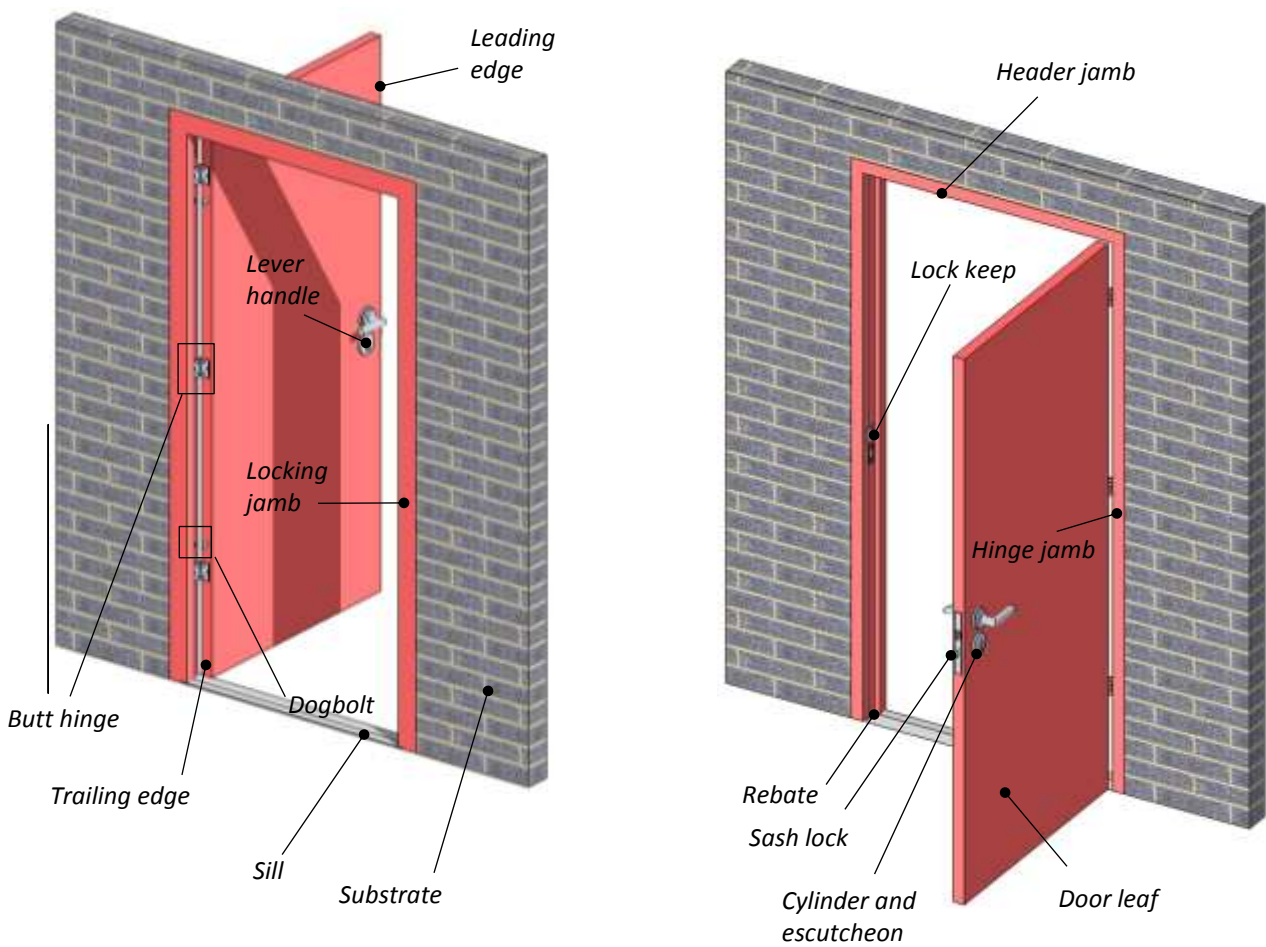

Door leaf

A doorset can be configured to have one or more leaves depending on the size of the opening to be secured.

Single leaf doorsets are generally the most secure. This is due to the stiffness of the frame adjacent to the lock providing direct support to that edge of the leaf.

Double leaf doorsets incorporate two leaves that hinge away from each other. They therefore tend to be more vulnerable to attacks aimed at levering or wedging open the leaves than single leaf doorsets. This is because the meeting edges of the two leaves are not constrained in the same way as the leaf and frame on a single leaf doorset. Particular attention must therefore be paid by the manufacturer to ensure the lock bolts holding the two leaves closed cannot be disengaged. This typically involves:

- enhancing the reinforcement between the meeting edges of the leaves to ensure they are stiff enough to prevent them deforming sufficiently for tools to pass between the two leaves and to prevent the leaves being levered apart;
- fitting locks with bolts that engage into the floor (sill) and frame above the leaf (header) as well as between the two leaves.

The leading edges of the leaves on double leaf doorsets (otherwise known as 'meeting stiles') should either have rebated edges or be fitted with astragals, as illustrated in Figure 3. It is recommended that plain (square) edged meeting stiles should not be used. This is because they tend to deliver significantly less resistance to attempts to lever the leaves open.

The leaves on double leaf doorsets are generally of equal width. However, in some cases the leaves may be of unequal width (these are often referred to as 'leaf-and-a-half' doorsets). This generally does not affect a security doorsets' ability to resist forced entry. However, in some cases it may be possible for an intruder to cut completely across very narrow leaves. It is therefore important to ensure the configuration used is correctly assessed by a suitably competent independent authority if the original doorset tested did not incorporate unequal leaves. Please contact your CPNI adviser for further advice.

The leaves on security doorsets should, where possible, open away from the protected area (i.e. they should be outward opening doorsets). This is because such doorsets tend to offer significantly more resistance to being rammed open (because the edges of the leaf are supported by the rebate within the frame) and can exhibit greater resistance to being levered or wedged open. Nonetheless, a well-designed inward-opening doorset (leaves open into the protected area) may also provide a good degree of resistance to forced entry.

Other configurations such as bi-directional (leaves open in both directions, otherwise known as swing doorsets) tend to offer significantly less resistance to forced entry and have therefore not been covered in detail in this guide.

Figure 3 Alternative meeting stiles on double leaf doorsets



(Typical outward-opening double door configuration)

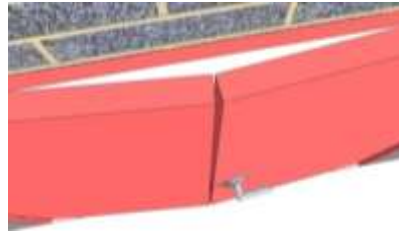

Plain meeting stile

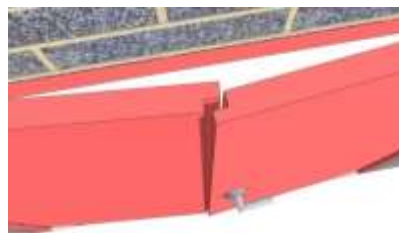

Rebated meeting stile

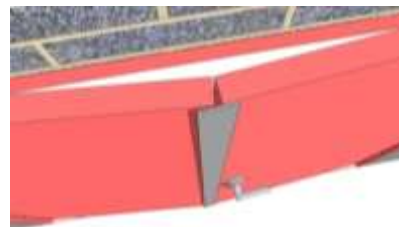

Astragal

The door leaf may be of a plain design (i.e. a flat panel), or may incorporate the following features:

- moulded profiles
- opaque infill panels
- glazed apertures (vision panels)
- ventilation grilles, such as louvre panels

It is recommended that vision panels and ventilation grilles are not placed in or near to security doorsets. This is because they may significantly reduce a doorsets' resistance to forced entry. For example:

- intruders accessing and operating the lock release mechanism on the rear of the doorset (e.g. lever handle);
- intruders accessing locking hardware fixings at the rear of the door.

However, it may not be possible to avoid fitting such features in some instances. Therefore, where such features are required, it is important to ensure they are covered by the scope of the doorset's forcible entry performance classification and offer commensurate security.

Door frame

A door frame is typically formed from the following elements:

- two vertical sides (jambs)
- a header, linking the tops of the two vertical jambs
- a sill

Frames will generally be rebated as illustrated in Figure 2. This is because the rebated edges within the frame support the sides of the leaf, helping to prevent tools being inserted between the two by intruders wishing to lever them apart.

The depth and width of the rebate will depend on the doorset. Generally, the deeper and wider the rebates, the harder it is for tools to be inserted through the gap between leaf and frame to lever/wedge the door leaf open.

In some cases no sill will be present, e.g. in corridors where trip hazards must be avoided. In those instances the floor continues beneath the door leaf. In other cases a flat or stepped sill may be installed. It is important to ensure the sill present on the doorset is covered by the scope of the doorset's forcible entry performance classification.

Hardware

A doorset will incorporate a range of hardware which attach the leaf to the frame and enable the leaf to be operated. The hardware will include:

- locking devices and their associated keeps (page 23)
- hinges (page 34)
- Dog bolts (page 35)
- other hardware, such as vision panels and door viewers (page 19)

The hardware specified must provide appropriate functionality and performance, and must not undermine the doorset's ability to deliver the performance required of it. It is therefore important to ensure the hardware selected:

- has been independently tested and certified to confirm it meets the relevant hardware classification requirements defined in the associated hardware standards^f;
- is commensurate with the performance requirements identified in the OR.

^f Refer to Appendix B.

Other features

Doorsets may also incorporate the following features:

- vision panels
- door viewers
- alternative thresholds
- side panels (i.e. panels to the side of the leaf which are typically fixed in place)
- over panels (i.e. panels above the door leaf). These may be fixed or removable.

It is important to ensure that these, and any other features specified, do not undermine the doorset's ability to deliver the performance required of it.

Vision panels

Vision panels may be required in order to comply with statutory requirements (see page 9) or to allow those within the secure building to observe those requesting entry into the premises.

Regulations normally dictate the use of toughened or laminated (6.4 mm thick) glass. This will not offer sufficient security for use in security doorsets. Specialist laminated security glass incorporating multiple layers of polycarbonate and hardened, in some cases, steel grid is required.

Figure 4 Access hole formed in a 6.4 mm thick laminated vision panel using basic hand tools



Incorporating a vision panel may introduce additional vulnerabilities, e.g. if the doorset is secured by a lock that can be operated from the protected side of the leaf by a single-handed release mechanism (see Appendix D). CPNI therefore recommends **not** using vision panels in doorsets, especially at HIGH protection level.

Please contact your CPNI adviser for further advice if the doorset needs to incorporate a vision panel.

As an alternative to vision panels, it may be appropriate to consider:

- **video entry systems** which provide users with sight of what is on the other side of the doorset, or a detection system which alerts the user to the presence of people/objects behind the doorset (if the doorset is an inward opening doorset used on a thoroughfare);
- **routes** within the building designed to avoid the risk of accidental impact by ensuring doorsets only cater for 'one-way traffic';
- **a pair of doorsets**, one with vision panels and one without, forming a secure lobby. Only the doorset facing the un-secure area (i.e. the external doorset) is required to have a vision panel. This configuration is demonstrated in Figure 5.
- **multiple glazed doorsets** forming a secure lobby with each doorset providing a part of the total resistance to intrusion required of the whole assembly.

Figure 5 Example of secure lobby with internal vision panel doorset

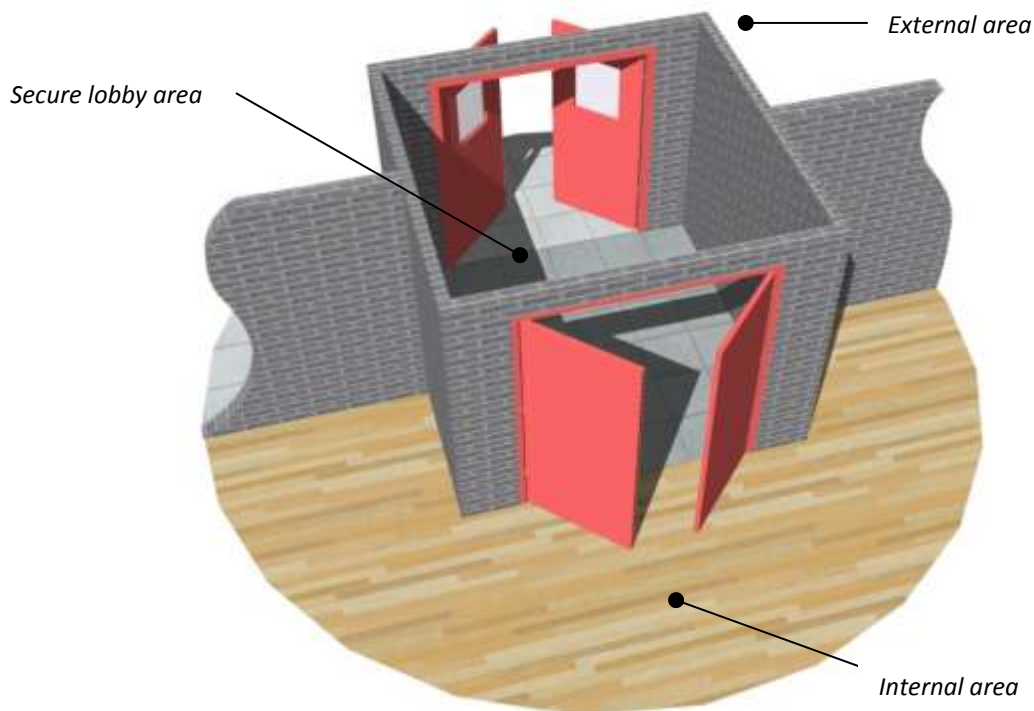

Door viewers (spy glasses)

It is important to consider whether door viewers are absolutely necessary. This is because an intruder can exploit the door viewer by shattering the optics or forcing the viewer out of the leaf and using the pre-formed hole through any anti-drill material in the door leaf to either:

- access and manipulate lock operating hardware on the rear of the doorset in order to retract the lock bolts and open the door leaf; or
- cut the leaf to create a larger aperture through the leaf or manipulate exit devices.

If it is necessary to fit a door viewer, it is important to ensure that it does not compromise the doorsets' ability to deliver the protection level required.

As an alternative to fitting door viewers, consider using video entry systems or similar.

Ventilation panels

Louvred or mesh vents/grilles may be required within a doorset to provide ventilation for equipment with high airflow requirements (e.g. substations, server rooms, plant rooms, etc.). Such vents are typically located at the top and bottom of each leaf or may be fitted to panels directly above the door itself. Alternatively, the entire leaf may take the form of a louvre vent or mesh panel.

The inclusion of ventilation panels may significantly reduce a doorsets' resistance to forced entry. It is therefore recommended **not** to include ventilation panels in or near to doorsets.

Side and overhead panels

The construction and installation of side panels and overhead panels must be commensurate with that of the doorset.

Door hardware

The term 'hardware' can be used to describe any item or component fitted on or within a doorset. This includes (but is not limited to) hinges, cylinders, cylinder guards or escutcheons, handles, vision panels, etc. This section concentrates on aspects associated with the locking hardware.

In all cases it is important to ensure that the hardware specified provides appropriate functionality and performance, and does not undermine the doorset's ability to deliver the performance required of it. It is therefore important to ensure the hardware selected:

- has been independently tested and certified to confirm it meets the relevant hardware classification requirements defined in the associated hardware standards^g; and
- is commensurate with the performance requirements identified in the OR.

Locking hardware

Locking hardware used to secure doorsets can be categorised as follows:

- Whether the lock is fitted within the door leaf (morticed), surface mounted (e.g. rim locks) or is a supplementary locking device fitted to the doorset only when the door is locked, e.g. a padlock.
- The number/layout of the bolts, i.e.
 - 'single-point' locking systems. These incorporate either one bolt or a local cluster of bolts, e.g. a deadbolt and a latch bolt;
 - 'multi-point' locking systems. These incorporate two, three or more bolts which usually engage in different directions.
- Whether or not the bolts engage automatically and/or deadlock automatically.
- The mechanism(s)^h fitted to the lock to release the bolts when the doorset is to be opened, for example, turn knobs, lever handles, push pads and panic bars.
- Whether the lock is mechanically operated, electromechanically operated (e.g. by an access control system linked to a solenoid located within the lock mechanism) or electromagnetic locks (commonly referred to as 'maglocks' or 'shear locks').
- Whether the locking system is designed to 'fail safe' or 'fail secure'ⁱ.

Each of these can affect the doorset's resistance to forced entry.

^g Refer to Appendix B.

^h Alternative types of operating hardware are described in Appendix E.

ⁱ Further details of the differences between 'fail safe' and 'fail secure' are provided in Appendix B.

Lock position

Surface-mounted locking systems have a number of advantages over morticed locking systems.

- They are generally easier to install. This is because it is not necessary to rout out a section of the door leaf to accept the lock body.
- They can incorporate larger bolts. This is because they are not constrained by the thickness of the door leaf, whereas the size of components used on mortice locks is restricted by the thickness of the door leaf within which the lock is installed.
- They are protected by the entire thickness of the door leaf. An attacker therefore needs to penetrate the complete thickness of the leaf or frame to access surface-mounted locking systems, whereas they only need to penetrate a much thinner portion of the leaf or frame before they can access a mortice locking system.
- The keeps into which lock bolts engage are supported by the full thickness of the door frame. This enhances their resistance to disengagement from the frame during attempts to lever the leading edge of the door leaf open.

Figure 6 Illustration of differences between surface-mounted locks and mortice locks

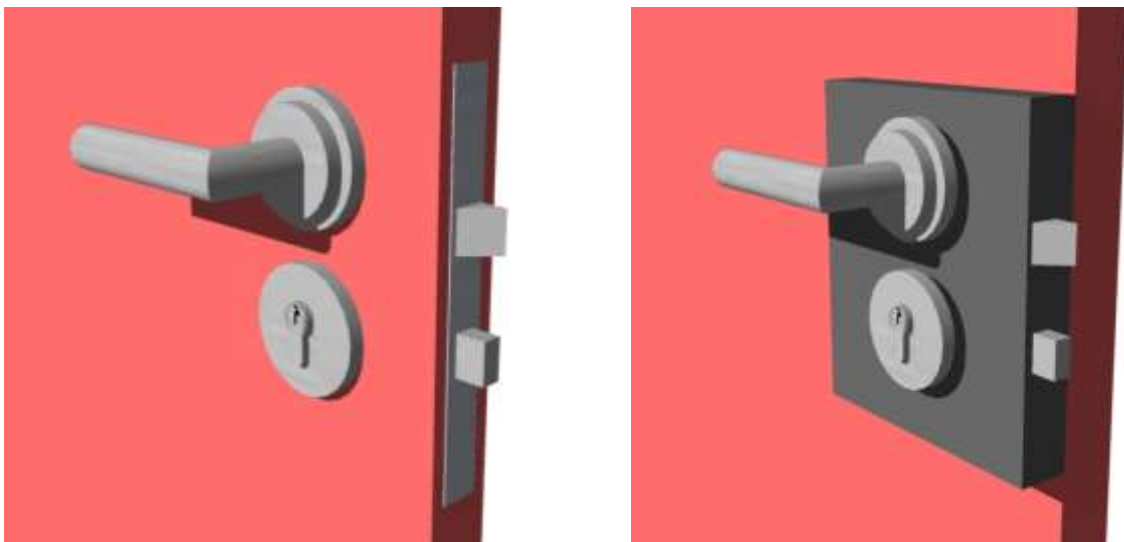

Mortice lock

Surface-mounted lock

Number and layout of bolts

Historically, the number of bolts present on the lock generally increased according to the degree of resistance to forced entry that the doorset was required to deliver. This was because the increased levering and wedging forces applied by intruders were dissipated through the bolts into the leaves.

However, it is important to remember that a lockset does not only have to resist levering attacks. As such, its resistance to forced entry is not only a factor of the number of bolts it incorporates.

The recent advent of larger, more resistant, single-point locks has enabled doorsets to resist sustained forced entry attempts without requiring the use of multiple locking bolts.

The bolts on these single-point locks are generally much larger (i.e. they have a greater cross-section) and have a greater throw (thereby allowing a greater engagement of the bolt into the keep) than the bolts on multi-point locking systems. The lock casing and fixings used to attach single-point locks are generally also of a much heavier duty in order to resist the levering forces applied by intruders.

Figure 7 Examples of doorsets with 'single-point' and 'multi-point' locking hardware

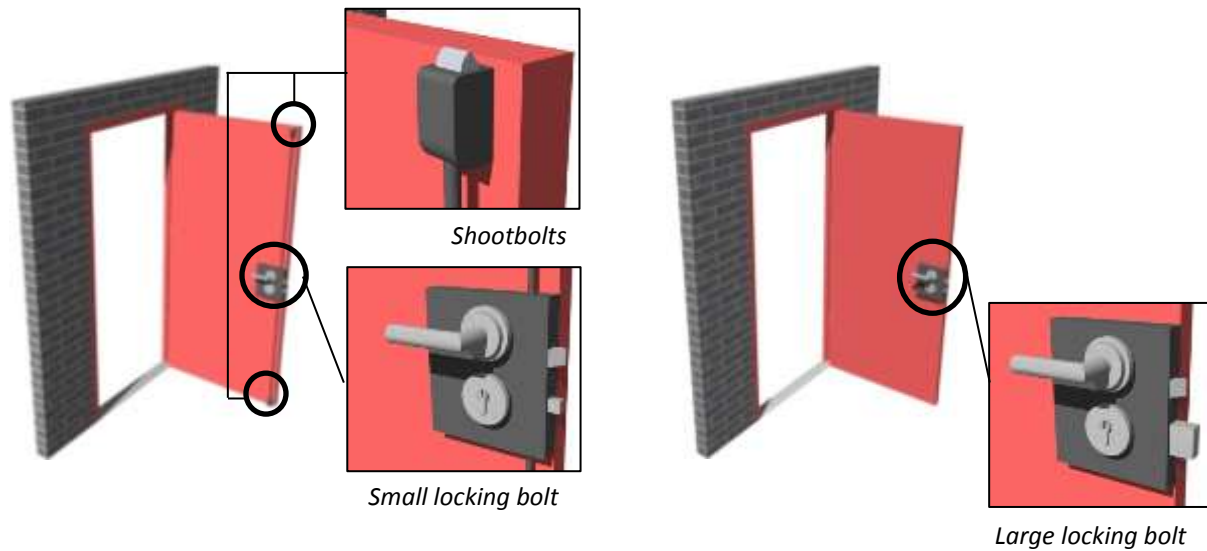

Typical multi-point locking arrangement

Typical single-point locking arrangement

Auto-bolting

The most common example of an 'auto-bolting' lock is a latch. It is important to note that unless the latch is deadlocked, it could be possible to disengage it by operating the handle or other devices without the need for a key or authentication feature. The bolt therefore needs to be deadlocked to prevent unauthorised access into the protected area.

Non-auto-bolting locks, i.e. locks whose bolts do not engage automatically, are often referred to as 'manually bolted locking systems'.

Auto-deadlocking

Locks whose bolts automatically deadlock are often referred to as auto-deadlocking locks, while those that do not are typically called manually-deadlocking locks.

Locks fitted to security doorsets typically incorporate auto-deadlocking systems. This is to ensure that the doorsets are not accidentally left in an unsecured condition (i.e. latched). However, it may not be appropriate to use such locks in certain circumstances, especially where there is a high chance of doorsets accidentally closing, leaving legitimate users of the secured environment locked out.

External lock operation

There are various ways to operate the deadlocking mechanism within a lock from outside the doorset. These include:

- mechanical keys which operate lever locks
- mechanical and electromechanical cylinders
- mechanical combination dials
- electronic key pads
- token readers

This section deals with mechanically-operated locking devices. Electronic locks are covered in CPNI's *Assured Automatic Access Control Systems (for pedestrian systems)* issued 2012.

Cylinders and cylinder guards

Cylinders can be extremely vulnerable to attack. It is therefore recommended that where cylinders are fitted, the ends of cylinders on the external faces of doorsets are protected within cylinder guards, offering appropriate resistance to attack.

Figure 8 Example cylinder guard with spinning disc (left) and rose (right)

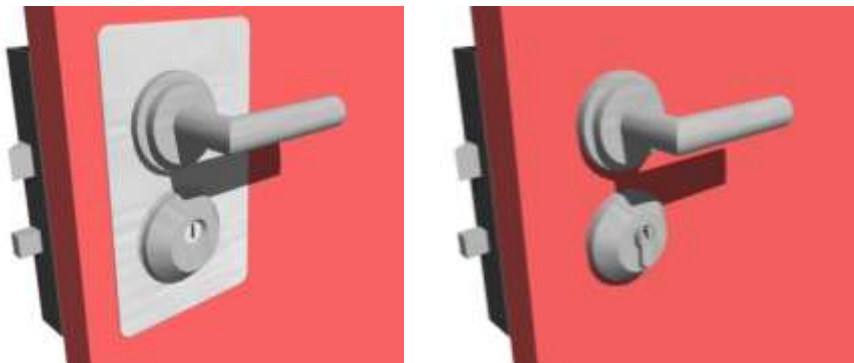

Escutcheons (also known as 'cylinder roses') fit over the end of the cylinder to provide support, and therefore help to resist attempts to snap or chisel off the end of the cylinder. However, they do not protect the cylinder from drills or attempts to drive tools into the key slot and force the cylinder to turn. They do not offer protection commensurate with the requirements of BASE Protection Level defined in CPNI's PBAS. This is because most cylinders are vulnerable to drilling, even those cylinders that meet the highest drill resistance classifications defined in the European standard for cylinders (BS EN 1303: 2005).

Cylinder guards generally provide greater resistance to attack. This is because they protect the entire end of the cylinder. To achieve this, they incorporate a spinning disc in the front of the guard. This contains a slot which permits the key to pass through the disc and into the cylinder while preventing other tools being driven into the key slot or the end of the cylinder being drilled.

Figure 9 Cross-sectional diagram of a cylinder guard incorporating spinning disc

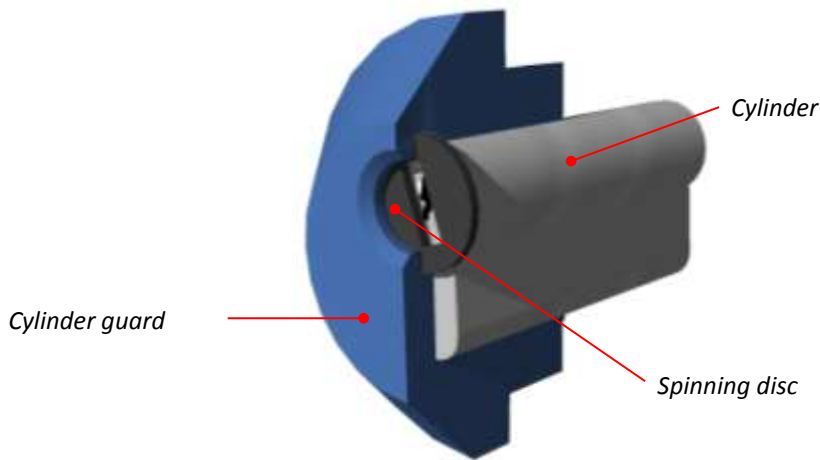

The disc itself may be formed from hardened steel (e.g. manganese steel) in order to prevent the disc being drilled.

The design and construction of the cylinder guard depends on:

- the level of attack resistance required;
- the type of cylinders to be protected (e.g. Europrofile, Scandinavian oval, rim, screw-in);
- the model of cylinder and design of the key used to operate the cylinder;
- the locking system to which the cylinder guard is designed to be secured; and
- the thickness of the doorsets to which the cylinder guard is designed to be fitted and the material from which that doorset may be manufactured.

In general, it is not possible to interchange one lock company's cylinder guard with that of another company without significantly affecting the protection afforded by the finished assembly due to differing fixings. While it may be possible to interchange cylinders within the guard, it is important to ensure both components are compatible.

Although some electromechanical cylinders (sometimes referred to as mechatronic cylinders) may not be as prone to drilling attacks as mechanical cylinders, they should still be protected by a suitable escutcheon or cylinder guard to prevent removing the cylinder from the door leaf.

It is important to note that, irrespective of the resistance to forced entry provided by the cylinders and associated guards protecting them, the protected environment will be vulnerable to unauthorised entry if there is inadequate key control^j.

^j See page 42.

Internal lock operation

There are various ways to operate a deadlocking mechanism from the protected side of the doorset. These include:

- mechanical keys which operate lever locks
- mechanical and electromechanical cylinders
- mechanical combination dials
- electronic key pads
- token readers
- thumbturns
- lever handles
- push pads
- panic bars
- combinations of the above

Some of these operating mechanisms are more vulnerable to door release manipulation than others.

Door release manipulation describes specific methods of attack involving penetration of the door leaf, features of the door leaf (such as vision panels or louvres), the door frame, or the structure within which the doorset is installed. An intruder then proceeds to use tools to manipulate the locking hardware release mechanisms (listed below in order of vulnerability to such methods of manipulation) in order to release the locking bolts:

- panic bars
- panic pads
- push pads
- lever handles
- unsprung thumbturns and turnknobs
- sprung thumbturns and turnknobs
- key operated cylinders

All doorsets must (at minimum) resist the creation of a full-body access aperture^k through the fabric of the leaf, irrespective of the method by which the locking hardware fitted to the doorset is operated.

Doorsets fitted with key-locking cylinders on the internal face must also resist the creation of holes directly through the door so that an intruder could manipulate the internal cylinder.

Doorsets fitted with thumbturns on the internal face must also resist the creation of 'hand-sized' holes through the leaf close enough to the lock to reach through and operate the thumbturn. Such doorsets should typically include additional protection local to the lock (when factory fitted with such locking devices) or require a suitable shroud to be fitted around the thumbturn if such a lock is retrofitted to an existing doorset.

^k The full-body access aperture is defined within CPNI's PBAS standard and LPS 1175, as that through which an elliptical test block measuring 400 mm by 225 mm may be passed.

Doorsets fitted with emergency or panic exit hardware must also resist the creation of much smaller holes (as little as 6 mm diameter) through which the lever handle, push pad or panic bar can be operated. The thickness of drill protection fitted within doorsets operated by panic hardware tends to be greater than that in other doorsets and extends across a much greater area.

As an alternative to inclusion of anti-drilling material within the leaf, it may be possible to retrofit a suitable shroud around the hardware operating devices located on the protected side of the doorset. However, it is important to ensure that such shrouds:

- do not undermine those devices' normal operation; especially if they are relied on to facilitate safe and reliable release in an emergency;
- do not create a safety hazard, e.g. sharp edges or crushing points, which may cause injury to those using the doorset; or
- prevent manipulation of the operating device via adjacent walling.

Locks for Automatic Access Control Systems

Various types of lock may be linked to access control systems. These are described below.

Guidance on access control systems to which these locks may be linked is available in CPNI's *Assured Automatic Access Control Systems (for pedestrian systems)* issued 2012.

Electromagnetic locks

There are two primary types: maglocks and shear locks.

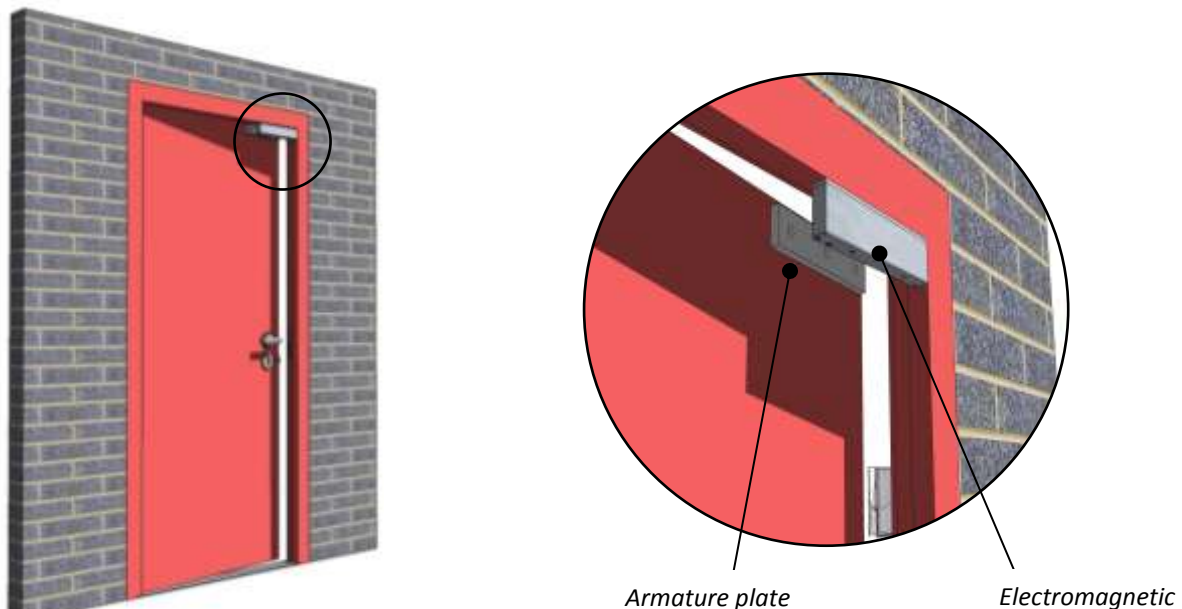

Figure 10 A maglock, viewed from the protected face of a doorset

Maglocks comprise an electromagnet and an armature plate. The electromagnet is attached to the frame on the protected side of the doorset, while the armature plate is usually attached to the protected side of the door leaf via a bracket. Power is fed to the electromagnetic in order to secure the door in the closed position. This creates a magnetic field which attracts the armature plate.

Maglocks' durability and speed of operation can make their use desirable in environments where there are large volumes of people movements through the doorway and electronic authentication of those passing through the doorway is required. However, maglocks have a number of vulnerabilities:

- they require a constant power source to remain locked. They disengage if the power to the lock is interrupted or falls below the level required to create sufficient magnetic flux to hold the door leaf closed;
- they cannot withstand the same levels of levering or impact forces applied to the door compared with alternative types of locking system.

Shear locks use the same principles of electromagnetism. However, instead of the meeting faces of the magnet and armature being parallel to the plane of the door leaf, they are perpendicular to the plane of the door leaf. This enables shear locks to be used on bi-directional doorsets, whereas maglocks can only be used on doorsets that open in a single direction. Grooves or pins located within the mating faces of the magnet housing and armature engage when the power is applied. These grooves (or pins) act as mechanical stops whose shear resistance is significantly greater than the folding force that can be achieved by maglocks. It is this 'shear' effect that lends its name to this type of electromagnetic lock.

Shear locks can be morticed in to the door leaf and frame, or surface mounted to the doorset. An example of a morticed shear lock is illustrated in Figure 11.

Like maglocks, shear locks require a constant power source to remain locked. They are therefore also vulnerable to unlocking if the power is interrupted or drops below the level required to create sufficient magnetic flux to hold the door leaf closed.

It is therefore recommended **not** to rely on maglocks or shear locks to provide security where there is a threat of forced entry.

Figure 11 *Morticed shear lock*

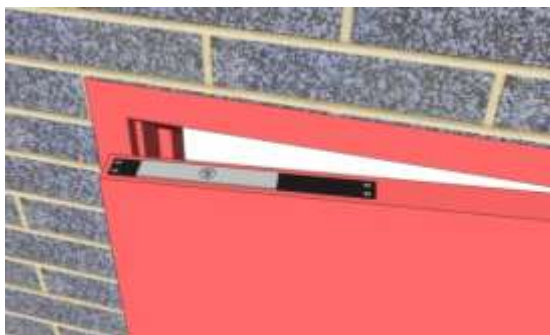

Plate fitted within the top edge of the door leaf



Receiver unit fitted within the header jamb

Electronic strike plates/keeps

Electronic strike plates (keeps) incorporate a strike plate on the face of the keep into which the latch bolt and/or lock engages when the door leaf is closed. The strike plate is a pivoted assembly that is retracted when the correct authentication is entered into the access control system to which it is linked. This enables it to be used with mechanical locks. However, the mechanism that operates the strike plate is often relatively vulnerable to manual attack compared with the construction of a normal strike plate.

Electronic strike plates tend to be extremely vulnerable to:

- strike plates being forced open, releasing the lock bolt. This is particularly the case when fitted to outward opening doorsets;
- deformation and fracturing of the keep during attempts to lever wedge or impact the door leaf;
- wear during repeated use. It is therefore important that they are regularly inspected and tested to ensure that they are functioning correctly.

Figure 12 Electric strike



Electronic strike plates are generally available in either 'fail-safe' or 'fail-secure' configurations. More recent variants may come with a switch enabling the mode to be alternated between 'fail-safe' and 'fail secure'.

'Fail-secure' electric strikes and multi-setting ones configured in the 'fail-secure' mode are vulnerable to the strike plate opening when the power to the electronic strike plate drops below the threshold required to maintain the strike plate in the closed position (e.g. due to a power failure or fire detection system linked to the keep triggering it to release).

It is therefore recommended **not** to:

- fit electronic strike plates to security doorsets, or
- rely on electronic strike plates to secure a doorset during periods when they may be subjected to sustained manual attempts at forced entry.

Electric locks

Many mechanical deadlocks on the market are available in electronically-operated formats. These most typically incorporate a solenoid within the lock body, which activates the deadbolt mechanism.

Solenoid-operated locks are generally available in fail-safe and fail-secure variants. They offer similar resistance to most methods of forced entry when compared with their mechanical cousins. However, they can be more susceptible to the following styles of attack:

- attacks aimed at driving the deadbolt out of engagement;
- impact attacks aimed at shocking the deadlocking components within the lock out of engagement to enable the deadbolt to be retracted;
- attacks aimed at accessing the wiring that feeds the power to the solenoid in order to cut it (fail-safe variants) and, on 'fail-secure' versions, apply sufficient power to the wiring to power the solenoid to disengage;
- the use of high powered magnets.

Heavier duty electric locks tend to incorporate motor mechanisms rather than solenoids. The lock bolts within electric motor locks are driven by a worm gear mechanism. They are often more resistant to attacks aimed at driving back the locking bolt than solenoid-operated locks.

Wiring

Locks linked to automatic access control systems require wiring for communication and/or power. The wiring should be protected by cable conduits to prevent them being exploited by an intruder. Conduits should either be concealed within the leaf or be surface-mounted on the internal face of the leaf. The latter is preferable because, as with surface-mounted locking systems, an attacker would need to penetrate the entire thickness of the leaf to access the conduit when mounted to the rear of the leaf.

Figure 13 Cut-away internal view of doorset to show wiring conduit located within a steel door frame

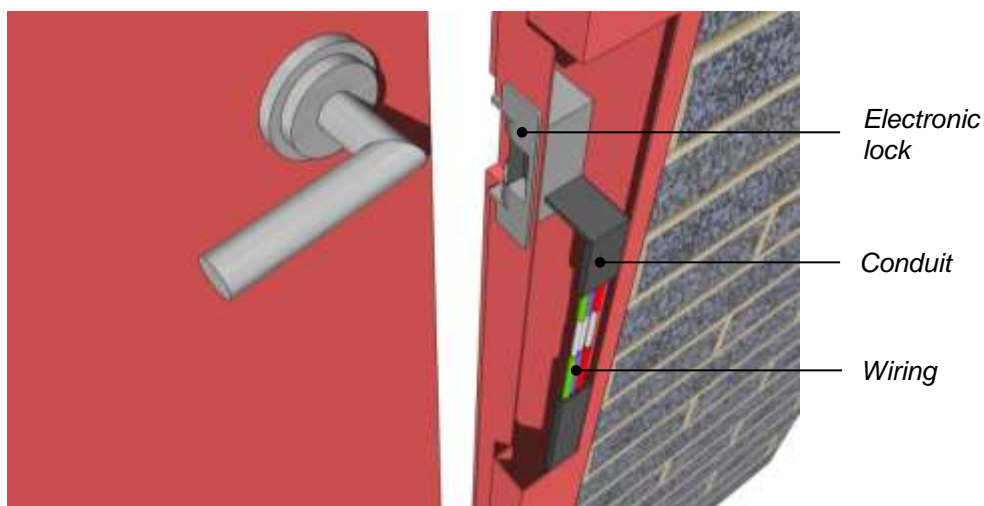

The wiring also needs to be adequately protected at all interfaces, e.g:

- between the door leaf and frame
- between the door frame and side or overhead panels
- between the door frame and supporting substrate

Power supplies and similar should be located within the secure building, beyond the reach of attackers.

For further information, see CPNI's *CNI Electronic Security Systems - Implementation Guidance*.

Electromechanical lock cylinders

As an alternative to fitting electronic locks, which often require wiring to be run to the door to power the locking devices, the use of electromechanical (mechatronic) cylinders may be considered. These can often be retrofitted to a lock in place of their mechanical cousins within the same family of locks. Providing the protection to the cylinder is maintained (i.e. in the form of the cylinder guard fitted to the attack face of the door leaf), the use of such locks generally should not compromise the doorsets' resistance to forced entry.

Modular locking systems

Modular locking systems consist of common central lock modules which can incorporate alternative mechanisms that facilitate the different types of lock operation described in Appendix D. A growing number of such systems are available.

The modularity allows locks within the same family to be interchanged more readily to provide different functionality. This is possible because they share a common footprint. However, it is important to note that the different functionality offered by the lock may affect the protection required to prevent manipulation of:

- the locking mechanism within the lock case
- the door release mechanism.

Locks sourced from different manufacturers rarely share the same footprint and so cannot be interchanged easily. These differences are likely to have a significant effect on the doorset's ability to offer the same resistance to forced entry to standards such as PBAS or LPS 1175.

Further guidance on interchangeability of locksets should be obtained from your CPNI adviser.

Padlocks

The security performance indicated by the European padlock standard (BS EN12320) provides very little indication of a padlock's resistance to the range of methods of attack covered by PBAS and LPS 1175. Padlocks should therefore not be selected primarily on the basis of their classification to BS EN 12320. Instead, attention should be paid to the rating attributed to the padlock either in accordance with PBAS or, when it is published, the LPS standard for padlocks¹.

¹ This standard, due to be published in late 2013, will be based on the principles of LPS 1175 and will classify a padlock's resistance to being removed from a standard hasp using the same tools and times as those specified within LPS 1175.

Most padlocks are vulnerable to manual attack. They therefore generally do not achieve a BASE Protection level (PBAS) or Security Rating 3 (LPS 1175) unless they are suitably shrouded.

Padlock shrouds

A number of doorset manufacturers have developed suitable shrouds, however these may inhibit the users' ability to attach the padlock and operate it.

Padlock shrouds fitted to doorsets



Other padlocks, even within the same product family, may be more vulnerable to attack because:

- the length of the padlock's shackle will affect the depth to which it hangs below the staple the padlock is attached to (see Figure 14);
- the size and profile of the body will affect the ability to fit the padlock; and
- features incorporated within the body or the cylinder mechanism housed within the padlock will affect its resistance to attack.

Figure 14 *Padlocks with exposed shackles and*

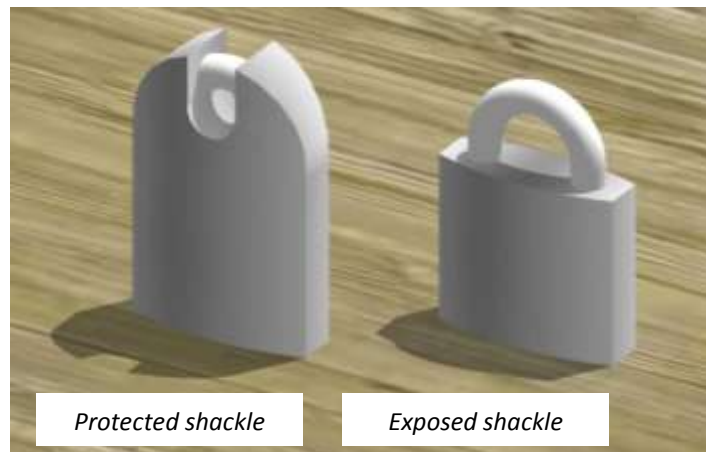

Padlocks are generally not suitable for use where people may become trapped inside the secured environment or where emergency egress is required.

At the time of publication (June 2013), a manufacturer has recently developed attachments for their multi-point and single-point locking systems which enable padlockable handles to be fitted to the external face of the doorset. These attachments enable the locks to be released from the inside of the door in an emergency using a choice of exit devices, while the external side of the doorset is secured against unauthorised ingress by a padlock.

Hinges

A variety of hinges is available (see Figure 15). Each type has potential vulnerabilities to attack. These are summarised in Table 2.

The hinges most commonly used on high security doorsets, due to their generally superior resistance to forced entry, are butt and piano/continuous hinges.

Table 2 Alternative hinge types and their potential vulnerability to forced entry

Type	Typical use	Description	Forced Entry Methods ^m			
			Shearing the fixings	Cutting the hinge knuckle	Knocking out the hinge pin	Inserting wedges between leaf and frame
Butt (loose-pin)	Timber, steel and composite doorsets	Hinge with a 'loose' removable central pin within the knuckle formed between the two flaps (leaves) that attach the hinge to the door frame and leaf.	✓	✓	✓	
Buttⁿ (security)	Timber, steel and composite doorsets	Hinge with a central pin secured within the knuckle to prevent its removal (e.g. using welds or grub screws).	✓	✓	✓	
Lift-off butt	Timber, steel and composite doorsets	Butt hinge with central pin fixed to one flap that can be lifted away from the other.	✓	✓		
Piano/continuous	Steel and composite doorsets	Extended version of a butt hinge, generally running along the full height of the door leaf.	✓	✓	✓	
Pivot	Glazed steel or aluminium bi-directional doorsets	Formed from pin located into roller pin assembly and housed above/ below the trailing edge of the leaf.				✓
Projecting	Rolled steel and PVC-u doorsets	Projecting arms joined by a mechanical fastener or lift-off pin.	✓ ^o	✓		

^m Boxes indicate the methods of attack which may be attempted in order to overcome the hinges.

ⁿ These are most commonly used on high security doorsets, due to generally superior resistance to forced entry.

^o On doorsets where the projecting hinge is mounted either with screws or rivets.

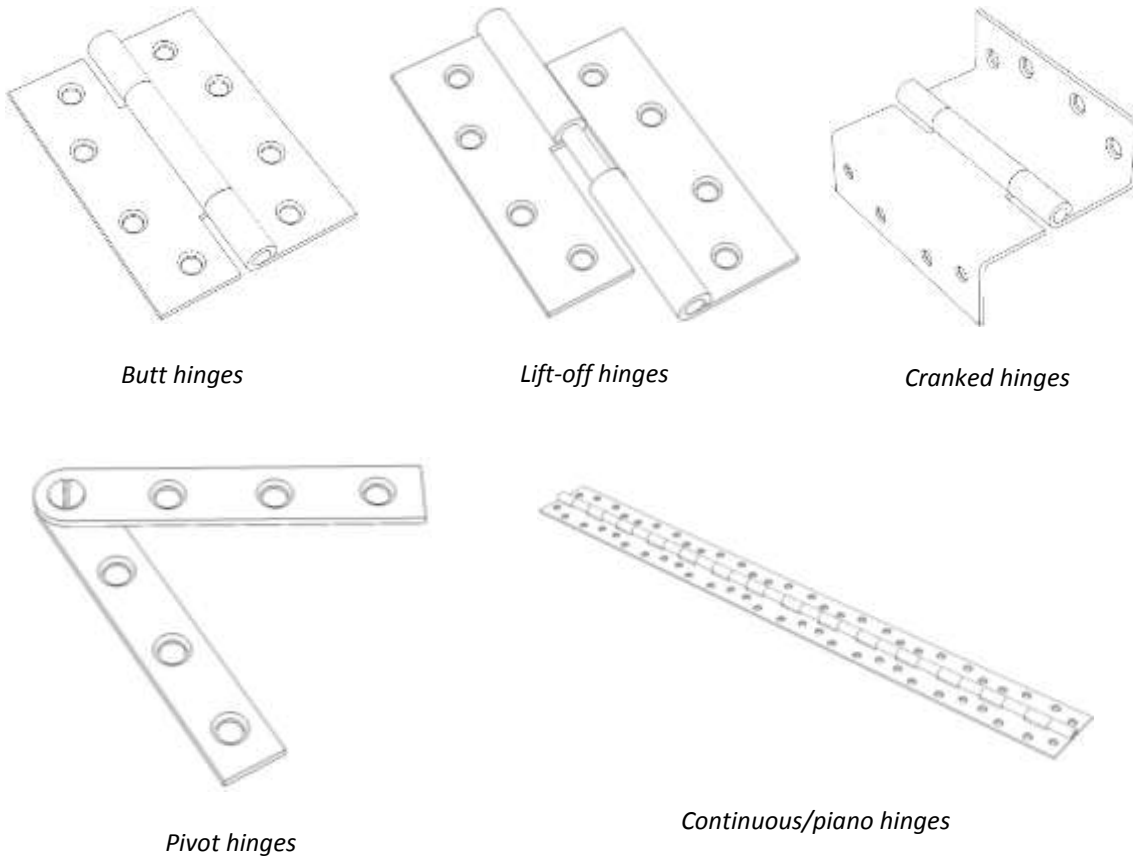
Figure 15 Hinge types*Butt hinges**Lift-off hinges**Cranked hinges**Pivot hinges**Continuous/piano hinges*

Dog bolts

Dog bolts are designed to prevent the hinge edge of the door leaf being levered open if the hinges are compromised. Dog bolts are either incorporated into the hinge mechanism (also known as hinge bolts) or as separate components fitted to the hinge edge of the door leaf, as illustrated in Figure 15.

Hinge bolts are often less effective at preventing attacks aimed at levering the trailing edge of the door open than separate dog bolts. This is because:

- attacks involving isolating the leaf of the hinge, to which the hinge bolt is attached, from the doorset also isolate the hinge bolt. This undermines the hinge bolts effectiveness at resisting the trailing edge of the door leaf being levered open once the hinges have been compromised;
- hinge bolts tend to be significantly smaller than dog bolts that are separately installed on the trailing edge of the door leaf. They are therefore generally more susceptible to cutting, shearing or deformation, as well as disengagement during attempts aimed at levering the trailing edge of the leaf open.

It is therefore recommended that separate dog bolts are fitted on security doors.

A number of designs exist. They are formed from hardened steel bars or pins, chamfered along one edge in order to prevent the dog bolt from interfering with the operation of the door leaf when it is opened and closed. Some take the form of a curved claw while others take the form of astragals running up the trailing edge of the leaf. These engage onto the rear of the door jamb during attempts to lever the trailing edge open.

Figure 16 Dog bolts/hinge bolts

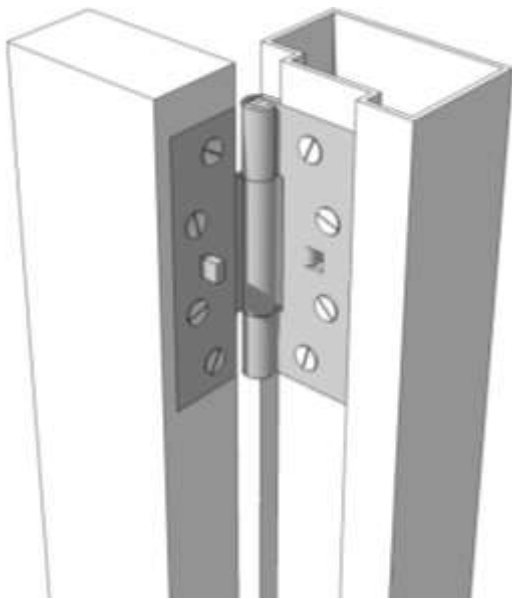

Hinge bolts incorporated within the hinge

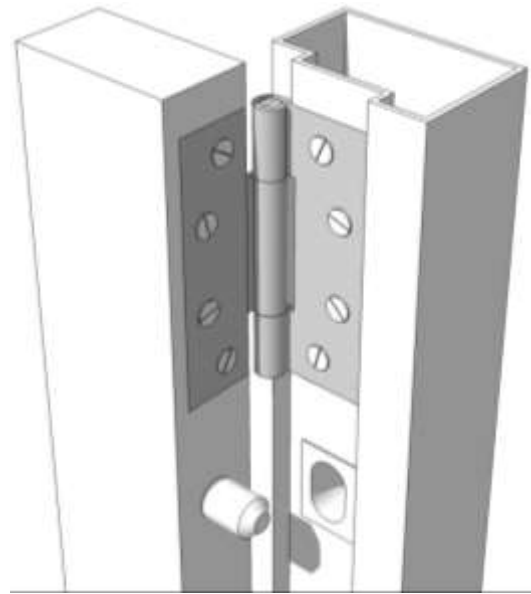

Dog bolts as separate components

Doorset installation and maintenance

It is important to ensure that the building fabric into which the doorset is fitted offers at least the same level of protection against forced entry as the doorset itself. There is little point in installing a security doorset into a building where the walls adjacent to the doorset do not provide adequate protection against the creation of a hole through which an intruder can pass, or reach and operate the locking hardware on the rear of the doorset.

Security doorsets tend to be very heavy. As such, their operation can impart significant loads onto the surrounding structure. This may result in fatigue cracking of the local structure if it is not suitably robust.

All fixings used to secure the doorset into the supporting structure should be concealed from those on the unprotected side of the doorset and, wherever possible, should also be concealed from those using the door.

All gaps between the door frame and surrounding structure should be packed out in accordance with the manufacturer's instructions, paying particular attention to ensuring that no gaps exist around installation fixings or in line with locks, hinges, dog bolts and joints between frame elements. This is to prevent deformation of the frame during attempts by intruders to lever the door leaf open or attack the installation fixings.

All doorsets should be regularly inspected to ensure that:

- their fabric is intact;
- there are no signs of tampering;
- all locking hardware remains firmly fitted to the leaf and frame;
- the fabric around the doorset is not showing any signs of degradation.

Any issues noted should be addressed in accordance with the manufacturer's instructions (see Appendix B) in a manner that ensures the continued conformity of the doorset with any security and other performance classifications (e.g. fire resistance) attributed to the doorsets.

There are a number of schemes for third party approval and inspection of doorset installers, as well as those who service and maintain doorsets. In the UK the most popular schemes are operated by LPCB^p (fire and security) and FIRAS^q (fire).

^p www.redbooklive.com

^q www.firas-database.co.uk

Forcible entry performance standards

It is important to specify and use doorsets which either:

- comply with CPNI's standard for determining the physical attack resistance of building elements (Physical Barrier Attack Standard (PBAS)); or
- are covered by valid third party certification^r to suitably recognised forcible entry standards, where appropriate. See Appendix C.

A number of standards exist for determining the forcible entry provided by doorsets. These are detailed below, in the approximate order of severity, starting with the most severe.

Physical Barriers Attack Standard (PBAS)

PBAS is CPNI's standard for determining the physical attack resistance of building elements, and other items. It is a top-up standard to LPS 1175 (see next section). The standard defines three 'protection levels', which are described within the following sub-sections.

Doorsets are assigned a protection level based on the results of forcible attack tests carried out on a sample of that doorset. The protection levels relate to the following:

- the attacker's skill and fitness, and prior knowledge of the doorset being tested;
- the tools available to the attacker, and complexity of the attack methods conducted using those tools; and
- the delay provided by the doorset to the creation of a hole or gap either large enough for someone to pass through or to operate the release mechanism on the rear of the doorset to open it.

CPNI uses two separate classification systems to indicate a doorsets' resistance to attack according to the nature of the threat:

1. Doorsets which provide resistance to asset theft and asset damage are attributed a CPNI Protection Level (i.e. BASE, ENHANCED or HIGH).
2. Doorsets which prevent undetected compromise of an asset are attributed a CPNI CLASS rating (i.e. 1, 2, 3 or 4).

These ratings and classifications are illustrated in Table 3.

Prior to 2009, doorsets which had been evaluated to determine their resistance to forced entry were attributed SEAP Class ratings. The term SEAP is no longer used and has been replaced by CPNI, which is trademarked.

Table 3 Summary of CPNI CLASS ratings and Protection levels

Asset type	Attack purpose		
	Undetected compromise of asset	Asset theft	Asset damage
Information	CLASS 1 - 4	Protection BEH	Protection BEH
Equipment	CLASS 1 - 4	Protection BEH	Protection BEH
People	N/A	N/A	Protection BEH
Buildings	N/A	N/A	Protection BEH

Note: There is no equivalence between a CLASS rating and a Protection level. A HIGH Protection level product does not automatically imply CLASS 4 undetected compromise protection, and vice-versa.

BASE: Doorsets which achieve this protection level provide resistance to forced entry by opportunist attackers with a general range of non-specialist hand tools, but a moderate resistance to more determined attacks.

Any doorset that meets the requirements of at least Security Rating 3 defined in LPS 1175: Issue 7 is also considered to meet BASE protection level.

ENHANCED: Doorsets which achieve this protection level provide a substantial resistance to non-specialist attacks but only a moderate resistance to more specialist attacks using very powerful tools.

HIGH: Doorsets which achieve this protection level provide a substantial resistance to a range of specialist forcible attack methods using powerful tools.

LPS 1175: Requirements and testing procedures for the LPCB approval and listing of intruder resistant building components, strongpoints, security enclosures and free-standing barriers.

The standard was originally developed by the Loss prevention Certification Board (LPCB) in the early 1990's to address concerns UK insurers had with regard to the quality of products used to secure commercial and industrial premises.

The two most recent versions of the standard (i.e. issues 6 and 7) define eight levels of resistance to attack, referred to in the standard as Security Ratings 1 to 8.

As the tool categories increase, the working time (the delay offered by the doorset) increases, as does the size and scope of tools the doorset is required to resist.

Copies of LPS 1175 and up-to-date details of doorsets approved to this standard are available to download from LPCB's website, www.redbooklive.com.

Further details of LPS 1175 are provided in Appendix B.

BS EN 1627: Pedestrian doorsets, windows, curtain walling, grilles and shutters. Burglar resistance. Requirements and classification^s, 2010.









It should be noted that, although the working times noted for each resistance class defined in BS EN 1627 match those defined in LPS 1175, doorsets rated to BS EN 1627 are likely to offer significantly less resistance to forced entry than doorsets approved to PBAS or LPS 1175. This is because the attack tools catered for within BS EN 1627, and the methods^t by which those tools may be used to attack a doorset, are significantly more restricted in BS EN 1627 than in CPNI's physical barrier attack standard (PBAS) and LPS 1175. In particular, the tests conducted to:

- BS EN 1627 resistance class 1 tests do not involve any manual attacks.
- BS EN 1627 resistance classes 1 to 3 tests do not involve any significant noise. This is because the standard assumes the intruders will not wish to make any noise gaining entry. This restricts the use of products' approved to these classes to environments where any noise made by an intruder will be immediately detected and responded to.
- Resistance classes 1 to 4 of BS EN 1627 do not involve any attacks on glazed panels and the attacks conducted on the locking hardware are also restricted. This can result in those features exhibiting weaknesses which may compromise the overall resistance to intrusion provided by the doorset.

^s BS EN 1627 defines the resistance provided by doors in terms of resistance classes (RCs). These 'classes' should not be confused with the CLASS ratings attributed to doorsets that provide resistance to undetected compromise by CPNI.

^t BS EN 1627 restricts how many of these tools are used. For example, steel tubes may not be placed on the ends of other tools to provide greater leverage or be used to impact the specimen. Neither PBAS nor LPS 1175 restrict tool use in that way.

Table 4 Summary comparison of working times and tools specified in LPS 1175: Issue 7 and BS EN 1627

Security Rating/ Resistance Class	Working Time (minutes)	LPS 1175	BS EN1627
1	1		
2	3		
3	5		
4	10		

PAS 24

PAS 24: 2012^u was produced by British Standards Institute (BSI) to provide a method for testing and assessing the 'enhanced' security performance requirements of single and double leaf hinged external door assemblies for dwellings and other buildings exposed to comparable risk.

PAS 24 is a largely mechanical test standard, requiring specimen doorsets to resist impacts and loads applied mechanically. This provides for much greater repeatability of results compared with the manual forced entry attack testing specified in PBAS and LPS 1175. However, the mechanical test methods do not allow for the variability in methods that may be attempted by those wishing to gain entry by forcible means. Although the standard includes a series of manual attack tests, those tests:

- are restricted to 3 minutes;
- involve a very restricted selection of small hand tools, which are prescribed by the standard according to the type of attack being conducted;
- preclude unconventional use of the tools used to attack the doorset; and
- preclude any significant impacting of the tools or of doorset being tested.

Doorsets meeting PAS 24 therefore tend to offer some resistance to levering and other methods of entry involving small hand tools that involve making negligible noise, such as cylinder snapping or bumping.

Figure 17 Tools specified in PAS 24 for glazing/infill panel removal (left), hardware manipulation (centre) and attempts to lever the door leaf open (right)



^u This replaced PAS 24:2007+A2:2011 *Enhanced security performance requirements for door assemblies – Single and double leaf, hinged external door assemblies to dwellings*.

Key control and use of key-safes

Effective key control is critical in ensuring that resistance to forced entry provided by a doorset is not undermined by unauthorised people gaining access to the keys. Unauthorised access allows:

- immediate use of the keys
- unauthorised copies of the keys to be made without realising they have been copied.

It is therefore important to introduce procedures to control the issue of keys and to ensure that the loss or theft of keys is reported.

Different levels of key control can be employed such that users only have authorised access to relevant areas, depending on their roles and responsibilities.

It is extremely important that a person's access to certain keys is determined by their role rather than their seniority.

Codes, tokens and fobs used in access control systems can be assigned similar levels of access. Refer to CPNI's *Assured Automatic Access Control Systems (for pedestrian systems)* for further guidance.

As well as keeping track of who has access to which key, it is important to prevent the unauthorised copying of keys. Cylinder manufacturers often use patented key designs and may employ additional measures such as requiring an identity card before duplicating keys. However, this does not protect against people loaning keys out and reporting them as lost. To mitigate against this, it may be beneficial to conduct a periodic audit of keys issued.

When not in use, keys (particularly master or grand master keys) should be securely stored with the departmental security team, and retained in sealed envelopes. Any keys issued by the departmental security team should be logged in and out appropriately; preferably within a given timeframe. Master or grand master keys should never leave the building or site.

Each key should be stamped with a number or symbol to relate it to a particular lock location, system or code.

Alternatively, keys should be securely stored in an appropriate container (i.e. security container, key box or key safe) located inside a secure area. It is important to ensure that the container's resistance matches that of the doorset. Otherwise, an attacker could compromise the container and obtain the key with relative ease rather than attacking the doorset itself.

If you are involved in the initial build phase of a new building design or a complete retro-fit design, it is recommended you use a temporary cylinder suite (often referred to as 'contract cylinders') that will be swapped out for final cylinders on site when the site or project is handed over. It is important that these are compatible with the lock and any cylinder protection provided by the lock and that the cylinders are only swapped by suitably trained personnel who are competent in commissioning the model of lock fitted to the doorset.

References

1. HMG Security Policy Framework Version 7. Cabinet Office, October 2011.
2. **LPS 1175:** *Issue 7 Requirements and testing procedures for the LPCB approval and listing of intruder resistant building components, strongpoints, security enclosures and free-standing barriers.* BRE Global Limited, June 2010.
3. **BS EN 1627:2011** *Pedestrian doorsets, windows, curtain walling, grilles and shutters. Burglar resistance. Requirements and classification.* BSI, June 2011.
4. **LPS 1270:** *Issue 1 Requirements and testing procedures for the LPCB approval and listing of intruder resistant security glazing units.* BRE Global Limited, November 2010.
5. **PAS 24:2007+A2:2011** *Enhanced security performance requirements for door assemblies – Single- and double-leaf, hinged external door assemblies to dwellings.* BSI, August 2011.
6. **PAS 24:2012** *Enhanced security performance requirements for doorsets and windows in the UK - External doorsets and windows intended to offer a level of security suitable for dwellings and other buildings exposed to comparable risk.* BSI, August 2012.
7. **PBAS:** Version 3.
8. **BS EN 948:1999** *Hinged or pivot doors. Determination of the resistance to static torsion.* BSI, December 1999.

Appendix A

Additional guidance on general doorset design and performance

Introduction

This appendix provides further guidance on issues covered within UK Building Regulations, as well as aspects associated with the general durability provided by the doorsets and their associated hardware which should be considered alongside their security performance when specifying the doorsets and their associated locking hardware.

Access to and use of buildings

Approved document M suggests thresholds on principal entrance doorsets, as well as those to other principal areas within a building, should preferably be level, i.e. with the adjacent finished floor level. If the threshold cannot be level, Approved Document M suggests:

- the total height of the threshold should not exceed 15 mm and the number of chamfers and slopes should be kept to a minimum;
- the edges of upstands of heights exceeding 5 mm are chamfered or rounded. This is to help reduce possibility of the threshold acting as a trip hazard or restricting the free movement of people in wheelchairs.

Direction and width of approach to the doorset	Minimum effective clear door width (mm) ^v	
	New buildings	Existing buildings
Straight on (i.e. without any turn or oblique angle of approach)	800	750
At right angles to an access route at least 1500 mm wide	800	750
At right angles to an access route at least 1200 mm wide but less than 1500 mm wide	825	775
Externals doors to buildings used by members of the general public	1000	775

Approved document M also suggests the principal entrance doorsets, as well as other doorsets providing access to other principal areas within a building, should:

- have the following effective clear width through a single leaf door, or through the primary leaf of multi-leaf door, when open:
- Be fitted with a self-powered opening and closing system unless:
 - it can be demonstrated that a person can open the door leaf using a force no greater than 20 N at the leading edge of the door;

^v The minimum effective clear width of a single leaf doorset is illustrated in Figure 18.

- the doorset is not required to be self-closing; or
- the doorset is held open during normal use. That is, the doorset is held open with an electromagnetic device that releases the door leaf when triggered to do so by a fire detection and alarm system, or when the power is cut, or when manually triggered to do so (e.g. out of hours).

It is therefore important to ensure any provision for self-powered opening and closing systems do not undermine the doorsets' resistance to forced entry, or that of its associated locking hardware.

- Not be fitted with any latching mechanisms, unless the operating devices that release the latching mechanisms can be operated using a closed fist (e.g. a lever handle or push pad)^w. In order to comply with Approved Document M, the operating devices should be located between 750 mm and 1000 mm above the finished floor level. This precludes the use of multiple locks with separate operating devices at various locations up the door leaf. Nonetheless, the use of multi-point locking hardware whose bolts are operated via a single lever handle or push pad can satisfy this requirement of Approved Document M whilst also being able to provide satisfactory resistance to the doorsets being levered open by attackers attempting to gain access through the doorset when locked.
- Incorporate vision panels on leaves and side panels greater than 450 mm wide. These should provide minimum zones of visibility between 500 mm and 1500 mm above the finished floor level that may be interrupted between 800 and 1150 mm above the finished floor level.

However, the inclusion of vision panels within a doorset can significantly reduce the doorset's resistance to forced entry (page 18).

Vision panels can also provide a means for people outside a secure area to view the secured area. Their inclusion within a doorset increases the risk of being able to see inside the room. Therefore, where possible, the use of vision panels within security doorsets should be avoided and other measures implemented to mitigate the risk of collisions occurring. Examples of such alternative measures include:

- use of 'one-way systems' within corridors^x.
- recessing doorsets which open outwards towards a corridor or other thoroughfare so that they do not open into the path of those moving past the doorway. However, it is important to ensure the recess does not inhibit a disabled person's ability to pass through the doorway. Guidance on the layout of approaches to doorways, in particular, the space required for wheelchair users around the leading edge of the leaf (i.e. the side of the leaf to which the handle is typically fitted) is provided in Approved Document M and British Standard BS 8300.

Note: Installing recessed, outward-opening doorsets has the following added advantages:

- It prevents the door leaf being impacted inwards, by virtue of the support provided to the sides of the doorset by the rebate formed around the edge of the leaf/frame.

^w This precludes the use of thumbturns, turnknobs, dial-type combination locks and many key pads on entrance doors designed to cater for those with reduced mobility.

^x Except in emergencies.

- It restricts intruders’ access to the edges of the door leaf; thereby enhancing the doorset’s resistance to methods of entry involving wedging or levering the edges of the door leaf to force the door open. However, it is important to ensure the edges of the recess cannot be used to provide fulcrums that enhance an attackers’ leverage when attempting to force the door leaf open. It is also important to ensure the edges of the recess are protected to prevent the door leaf impacting the edges of the recess when opened.
- Use of power-operated doorset, accompanied by audible and visible alarms to alert those close to the door that it is operating.

Note: If power operated doorsets are fitted in order to aid access by those less mobile, those doorsets should incorporate:

- safety features to prevent injury to people struck or trapped by a doorset (e.g. inclusion of pressure sensitive door edges which operate the power switch);
- a readily identifiable and accessible power switch; and
- provision for manual and automatic opening in the event of a power failure where and when necessary for health and safety.

Most importantly, an Access Statement must be prepared if the mobility measures implemented deviate from the recommendations contained within Approved Document M. Its purpose is to explain the rationale behind the deviation and why the measures implemented meet the intent of Approved Document M.

Durability

Table 5 summarises the minimum number of operations that doorsets certified to BS EN 1191: 2000 should be expected to deliver if installed and maintained in accordance with the manufacturer’s instructions.

Table 5 Minimum number of operations expected over the intended lifetime of a doorset according to its durability classification to BS EN 1191: 2000

Durability class defined in EN 1191: 2000	1	2	3	4	5	6	7	8
Total number of operations over lifetime of doorset (1000s)	5	10	20	50	100	200	500	1000

In order to maximise the lifespan of a doorset, it is important to reduce the likelihood of damage to the door, hardware or adjacent walls caused by careless use. It is therefore important to ensure that the doorsets incorporate kick plates and finger plates and that the provision of such plates does not affect the doorsets’ resistance to forced entry. It is also important to ensure that doorsets are either located a sufficient distance from adjacent walls, a perpendicular wall or other items, to prevent the door or its associated hardware impacting them when opened. Alternatively, doorsets should be fitted with door stops.

Fire safety

The minimum fire resistance a doorset is required to provide depends on where that doorset is located and the fire and emergency strategies for the building. Guidance on this is provided in Approved Documents B1 and B2, which deal with dwellings and non-dwellings respectively. The requirements contained in these Approved Documents are primarily designed to ensure occupants have sufficient time to escape if a fire occurs. Additional fire resistance may be required to protect rooms containing items of significant value or to reduce other possible consequential losses. Alternatively, lower resistance may be acceptable if sprinkler systems are designed and installed in accordance with LPS 1048-1: Issue 4 or BS EN 12845: 2004.

Likewise, the layout of escape routes and types of release mechanisms fitted to each doorset within a building will depend on the risk assessments and associated strategies implemented.

If a doorset is required to provide protection in the event of a fire and is fitted with a hold-open device to hold the door leaf open during normal periods of occupancy, that device:

- should be linked to the fire detection and alarm system;
- should release reliably in the event of the alarm system being triggered.

Such doorsets must also be fitted with suitable self-closing devices capable of closing the doorsets to a position in which they will deliver the required fire protection.

Special attention should be paid to doorsets leading to rooms (referred to as inner rooms) from which there is only one escape route, in particular, via another room rather than directly onto an escape corridor. Approved Document B2 recommends such doorsets incorporate a vision panel measuring at least 0.1 m² to enable occupants of the inner room to determine whether the fire has started in the outer room.

The size of doorset fitted will need to suit the number of occupants likely to need to pass through the doorset in the event of an emergency. Table 4, within Approved Document B2, makes the following recommendations:

Number of occupants	Minimum effective clear width (mm)
≤60	750
≤110	850
≤220	1050
>220	5 per person

Figure 18 Effective clear width of doorsets according to the angle to which the door leaf can open

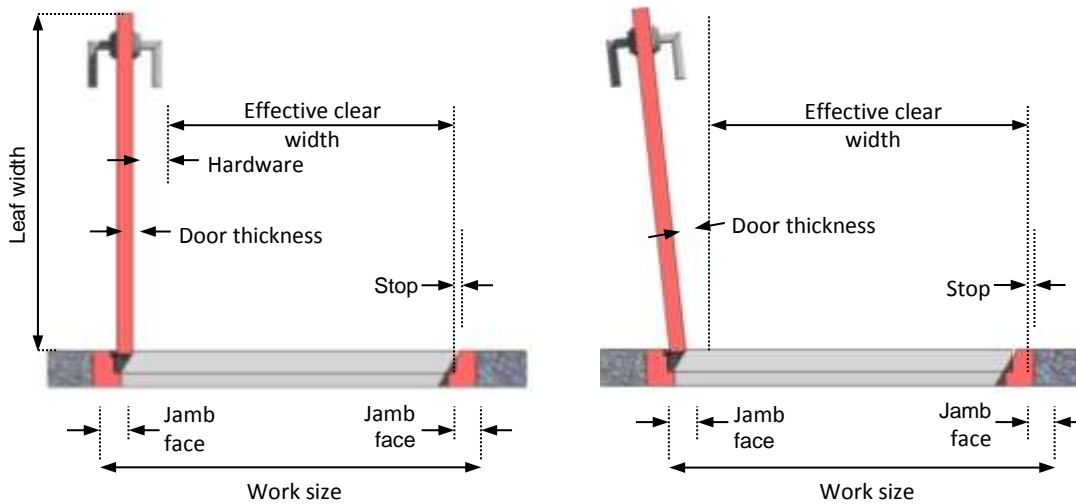

Doorsets fitted to escape routes must incorporate hardware that can be readily operated by people approaching the doorset to escape in an emergency. The hardware's operation should be readily apparent, without the need to use a key or other form of identification token, and without the need to manipulate two different mechanisms (e.g. a thumbturn and a lever handle). That is, a single handed means of releasing the door should be provided and this should generally be in the direction of exit^y.

This requirement also applies to doors secured using access control devices. Many high security locking systems incorporating solenoids linked to access control systems offer two options:

Fail secure: These ensure the security is maintained in the event of a power failure. Such devices should incorporate a one-handed means of escape on the side of the door from which occupants will be attempting to operate the door in an emergency. Such means of escape are:

- A lever handle or push pad. These systems should:
 - comply with the European standard for emergency escape hardware (BS EN 179); and
 - only be used where the occupants are familiar with the hardware's operation and a panic situation is not likely to ensue.
- A panic bar or panic pad, running across the width of the door. These systems should:
 - comply with the European standard for panic escape hardware (BS EN 1125); and
 - be used where the occupants may be unfamiliar with the hardware's operation and a panic situation may ensue.

^y This is particularly the case if the number of occupants likely to need to use the door to escape in an emergency exceeds 60, or in situations where there is a risk of rapid fire growth such as some industrial situations.

Fail safe: These release automatically in the event of a power failure and as such can result in the resistance to forced entry provided by the doorsets to which they are fitted being compromised if there is a power cut. It is therefore recommended that suitable uninterrupted power supplies are fitted with suitable back up or that the use of such devices is avoided.

Where the doorsets are also required to provide resistance to forced entry, it is important to ensure that the scope of the doorsets' or listing within CPNI's Catalogue of Security Equipment (CSE) or certification (within the Red Book) covers the width, leaf configuration (i.e. single leaf or double leaf), opening direction (which typically needs to be in the direction of escape), and hardware to be fitted to the doorset. This is to ensure compliance with the requirements of Approved Document B do not compromise the security provided by the doorsets.

Doorsets which provide combined certified security and fire performance tend to cost more than those offering only one type of performance. In some instances it may be appropriate to use two doorsets instead of one to achieve the required security performance or fire. For example, two 2 hour fire doors working in combination will deliver 4 hour fire resistance². Using two doors may also provide security benefits such as acting as a 'tiger trap'.

Irrespective of the fire resistance a doorset is required to deliver and the hardware fitted to the doorset, it is important to ensure that the interface between the doorset and surrounding substrate does not reduce the fire performance. Reference should therefore be made to the manufacturers' recommendations for secure installation details and to ensure they are covered by valid fire performance assessments and third party certification from a recognised third party certification body such as LPCB, BM Trada, or Exova.

Furthermore, the doorset's fire resistance may be significantly affected by the glazing, hardware and other items specified. It is therefore also important to ensure that those aspects are covered by the supporting evidence of third party certification submitted for those doorsets.

It is important that:

- fire doorsets are regularly inspected and maintained in accordance with the manufacturer's instructions by qualified service and maintenance engineers;
- the fire strategy and emergency plans are consulted before replacing or altering any fire resisting doorsets.

Health and safety

All work involving installation, maintenance and servicing of doorsets should be covered by a valid risk assessment and method statements.

The risk of fingers becoming trapped in doors should be considered – in particular on doors that will not be held open using hold-open devices during peak periods of pedestrian movement.

Consideration should also be given to the force required to operate higher security doorsets, because they tend to be significantly heavier than normal doorsets. This may be achieved by fitting power-assist devices. If doorsets are power-operated doorsets, they must meet the requirements of BS 7036: Part 1: 1996 *Code of practice for safety at powered doors for pedestrian use*.

² This is providing the other features of the fire compartmentation deliver the required fire resistance and both doors are capable of closing if a fire occurs.

Maintenance

Doorset manufacturers should supply maintenance instructions for the doorsets and associated hardware, which cover the following:

- cleaning
- decorating
- lubricating moving parts
- checking operating forces and functionality
- checking seals
- replacing damaged components
- maintenance of the hardware supplied on/with the doorset

Facilities management staff should ensure that all maintenance recommendations made by the doorset manufacturer are followed because the performance claimed by the manufacturer is likely to be conditional on such measures being implemented.

The maintenance regime should ensure that doorsets and their associated hardware are visually inspected on a regular basis to make sure they are free of defects and that all seals and fixings are in place and secure. This is particularly relevant to fire doorsets as removal of, or damage to, intumescent strips may undermine the doorsets' performance in a fire situation.

It is also important to ensure that the doorset continues to operate using forces below those defined within Approved Document M. This can commonly be checked using plunger-type force measuring instrument. Any increases in the force measured during maintenance checks beyond that measured during commissioning or previous maintenance checks may indicate problems that could be affecting the doorset's compliance with other performance requirements, such as fire resistance, acoustic performance, security and durability. It is therefore important to investigate the likely causes of any increase in the operating force and repair or replace the doorset / hardware as appropriate.

In order to ensure the continued performance of doorsets to the relevant standards, it is critical that the replacement components match those being replaced. If alternative components are sourced, for example, different locksets, it is important to ensure that the use of that alternative lockset is covered by appropriate third party assessments and does not invalidate any warranty or certification covering that doorset.

Safety against accidental impact

It is important to ensure that people can pass through a door or along a corridor without fear of someone opening a door into them. It is for this reason clause 5.2 of Approved Document K requires doorsets on main traffic routes, and those that could be pushed open from either side (i.e. bi-directional doorsets), to incorporate vision panels with a minimum zone of visibility covering the area shown in Figure 19.

As noted in Section 2, it is important to ensure that the glazing used does not compromise the doorsets' ability to offer the required resistance to forced entry and, in particular, that it cannot be compromised to operate the doorset release mechanisms fitted to the protected side of the doorset. Where such protection against intrusion cannot be assured, reasons for excluding vision panels (i.e. using a plain leaf doorset) must be included within an Access Statement and alternative measures for providing suitable access for authorised people implemented.

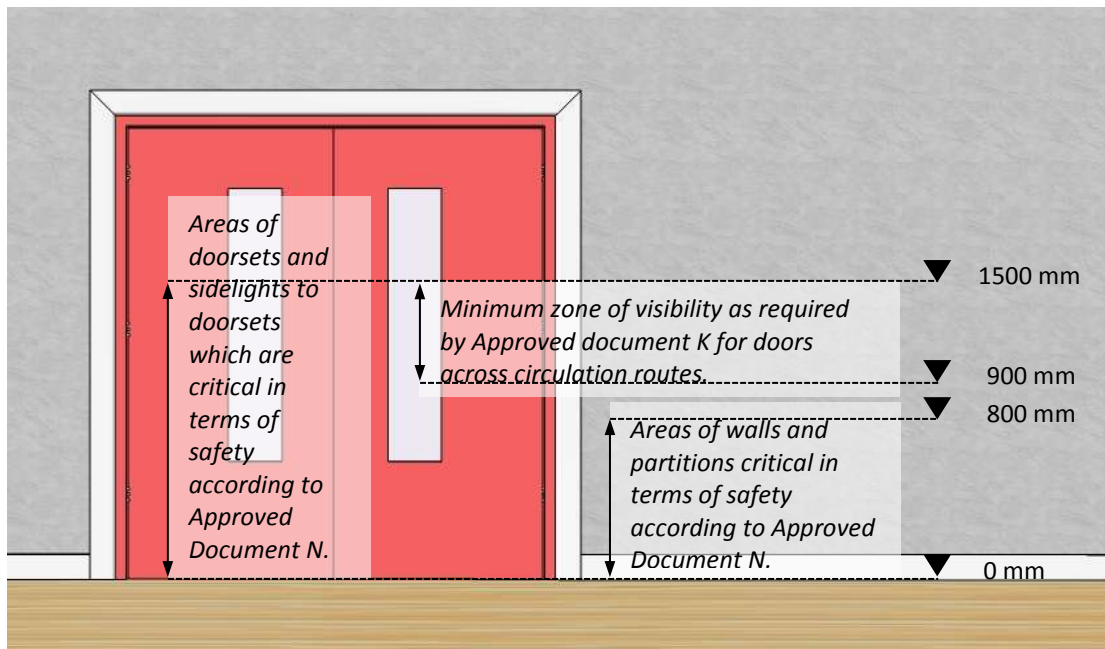
Figure 19 Doors with single vision panels

Approved Document N deals with issues associated with injury through accidental impact with doors and glazing. It identifies the area between the finished floor level and 1500 mm above that level on a doorset, or a panel to either side of a doorset, as being 'critical' in terms of safety. It recommends that glazing used in those areas should be robust (e.g. polycarbonate or glazing laminated with polycarbonate). Since glazing fitted to doorsets meeting the security performance requirements contained within PBAS or LPS 1175 will be required to resist manual attack, it is generally considered that security glazing will satisfy this requirement.

Thermal performance

Approved Documents L2A and L2B generally only affect external doorsets and how they are installed within the building envelope on non-domestic buildings. It states the minimum area-weighted average of all elements of that type within the building envelope should not be greater than the following U-Values:

- pedestrian doorsets, windows, roof lights and roof windows and curtain walling - 2.2 W/m².K.
- vehicle access and similar sized doorsets - 1.5 W/m².K.
- high use entrance doorsets - 3.5 W/m².K, providing those doorsets incorporate automatic closers and, where possible, are protected by a lobby.

Clause 5.3 of Approved Document L2A requires cold bridging to be avoided wherever possible around joints between apertures formed in the building envelope and the any doorsets, windows or other features installed within those apertures. It is important to ensure any detailing designed to ensure compliance with this clause of the Approved Document does not undermine the doorsets ability to resist removal from the building envelope, or undermine its resistance to penetration. Therefore, where such details fall outside the direct scope of a doorsets approval to the relevant security performance standard, an assessment should be sought from the associated approval body, or another competent third party, to confirm whether it is likely to compromise the doorsets' ability to provide the required security performance.

Appendix B

Doorset and lock performance standards

Introduction

This appendix provides further information about performance standards for doorsets and locks, in particular, the standards for physical security performance of doorsets commonly used in UK at the time this document was published.

LPS 1175: Issue 7

LPS 1175: Issue 7 *Requirements and testing procedures for the LPCB approval and listing of intruder resistant building components, strongpoints, security enclosures and free-standing barriers is published by LPCB*. It defines eight levels of resistance to attack: Security Ratings 1 to 8.

As the security ratings increase, the working time (i.e. the delay the doorset is required to deliver) increases, as does the size and scope of tools the doorset is required to resist. This reflects the increased investment an intruder may make in attempting to gain entry to a property according to the 'reward' they are seeking to obtain by gaining entry to the protected area. However, unlike CPNI's PBAS standard, LPS 1175: Issue 7 restricts the number of people attacking the product at any one time during test programmes to one person.

A number of changes have been made to LPS 1175 over recent years, not least the list of tools used to test products and the scope of techniques employed by the test team. It is therefore recommended that, where possible, doorsets meeting the latest version of the standard are specified.

Copies of the standard, together with details of doorsets (and other products) independently approved to the standard may be obtained free of charge from www.redbooklive.com.

Locking hardware performance standards

A number of British, European and Loss Prevention (LPS) standards for locking hardware exist. These standards are described in Table 6.

Although these standards classify the locking hardware as standalone products, locking hardware will not prevent unauthorised entry in its own right. The doorset and its associated locking hardware must work together effectively as a system to provide the required resistance to attack.

While the British and European standards include 'security classifications', the tests those standards define do not cover the scope of tools and attack methods that are covered within PBAS or LPS 1175. It should therefore not be assumed the hardware's compliance with associated British and European hardware standards mean the hardware is suitable for use on doorsets delivering resistance to forced entry and undetected compromise. It is therefore important to consult the CSE or Red Book to ensure the locks to be selected are compatible, that is, they do not undermine the doorset's security performance.

It should also be noted that many of the European hardware standards are only designed to cover hardware used on leaves of weights up to 200 kg. In the absence of standards covering the hardware's performance on heavier doorsets, specifiers should seek appropriate evidence of the doorset's

performance as an assembly rather than relying on data associated with the lock or other hardware used to assemble the doorset.

Many of the European standards define complex classifications that confirm the hardware's performance in terms of a number of different attributes. The Door and Hardware Federation have developed a series of icons (summarised in Table 7) to illustrate what the various classification digits indicate, and have also published some guides to the various standards. These are available to download from their website: www.dhfonline.org.uk .

In addition to specifying minimum performance requirements, the standards for exit hardware and handles also define critical dimensions of the operating devices. Further guidance on the dimensions of such hardware, e.g. handles, is contained in British Standard BS 8300 Design of buildings and their approaches to meet the needs of disabled people.

By restricting the scope of designs of the operating features possible, the standards restrict the options for designing the hardware to prevent manipulation of hardware attacks (see page 26). It is therefore important to ensure that the materials within the doorset deliver resistance to attacks aimed at accessing the operating devices that is compatible with the hardware fitted to the doorset.

Table 6 Standards for door hardware

Standard	Title	Description
BS EN 179: 2008	Building hardware. Emergency exit devices operated by a lever handle or push pad, for use on escape routes. Requirements and test methods	<p>This standard applies to mechanically-operated emergency escape hardware providing safe and effective escape through a doorset with a single operation (e.g. by turning a lever handle without first needing to operate a thumbturn or key-locking cylinder). The standard defines ten classifications:</p> <ol style="list-style-type: none"> 1. Category of use - high frequency of use where there is little incentive to exercise care (grade 3). 2. Durability - 100000 cycles (grade 6) or 200000 cycles (grade 7). 3. Door mass - Up to 100 kg (grade 5), up to 200 kg (grade 6) and over 200 kg (grade 7). 4. Suitability for use on fire/smoke doors. 5. Safety - Only one grade of safety exists, i.e. grade 1. This is because all emergency exit devices have a critical safety function, therefore only the top grade is identified for the purposes of this European Standard. 6. Corrosion resistance - 96 h salt spray (grade 3) or 240 h salt spray (grade 4). 7. Security - 1 000 N load (grade 2), 2 000 N (grade 3), 3 000 N (grade 4) or 5 000 N (grade 5). 8. Projection of operating element - projection up to 150 mm (grade 1) or projection up to 100 mm (grade 2). 9. Type of operation - lever handle (type A) or push pad (type B). 10. Field of door application.
BS EN 1125: 2008	Building hardware. Panic exit devices operated by a horizontal bar, for use on escape routes. Requirements and test methods	<p>This standard applies to mechanically operated panic exit hardware providing safe and effective escape through a doorset with a single operation of a horizontal push-bar (panic bar) or horizontal push-pad (panic pad or touch bar) without first needing to operate any other devices. The standard defines ten classifications:</p> <ol style="list-style-type: none"> 11. Category of use - high frequency of use where there is little incentive to exercise care (grade 3). 12. Durability - 100000 cycles (grade 6) or 200000 cycles (grade 7). 13. Door mass - Up to 100 kg (grade 5), up to 200 kg (grade 6) and over 200 kg (grade 7). 14. Suitability for use on fire/smoke doors. 15. Safety - Only one grade of safety exists, i.e. grade 1. This is because all emergency exit devices have a critical safety function, therefore only the top grade is identified for the purposes of this European Standard. 16. Corrosion resistance - 96 h salt spray (grade 3) or 240 h salt spray (grade 4). 17. Security - Only one grade of security exists (i.e. grade 2). This is because panic exit devices are primarily for the operation of a door from the inside and the standard considers security requirements to be secondary to those of safety. 18. Projection of operating element - projection up to 150 mm (grade 1) or projection up to 100 mm (grade 2). 19. Type of operation - push bar (type A) or push pad (type B). 20. Field of door application.

NOT PROTECTIVELY MARKED















Standard	Title	Description
BS EN 1300: 2004 + A1:2011	Secure storage units. Classification for high security locks according to their resistance to unauthorized opening	This standard covers high security locks, traditionally designed for use on safes. The tests defined within the standard assume the lock bolt engages into boltwork rather than directly across the joint between a door leaf and frame. Such locks should therefore not generally be used to directly secure a doorset but should instead be used to secure boltwork on a doorset.
BS EN 1303: 2005	Building hardware. Cylinders for locks. Requirements and test methods	Applicable to mechanical cylinders. The standard defines a number of requirements: <ul style="list-style-type: none"> • Minimum number of effective key differs and movable retainers. • Maximum number of identical steps. • Torque resistance of the cylinder or plug. • Resistance to drilling, chiselling, twisting and cylinder/plug extraction. • Other requirements such as fire and corrosion resistance. The standard defines an eight-digit classification. Digit 7 is key-related security, graded 1 (lowest) to 6 (highest). Digit 8 is attack resistance, graded 0 (lowest) to 2 (highest). However, this standard is not consistent with PBAS or LPS 1175. Refer to LPS 1242 instead, which is more compatible with PBAS and LPS 1175.
BS 3621: 2007 + A1:2009	Thief resistant lock assembly. Key egress	This standard is applicable to single-point locking systems where a key is required for exit. The standard incorporates the requirements of BS EN 1303 for cylinders and BS EN 12209 for locking hardware. It also includes manipulation tests, conducted by a panel of locksmiths, and 'cylinder bumping' tests.
BS 8621: 2007 + A1:2009	Thief resistant lock assembly. Keyless egress	This standard is applicable to single-point locking systems where a key is not required for exit. The standard incorporates the requirements of BS EN 1303 for cylinders and BS EN 12209 for locking hardware. It also includes manipulation tests, conducted by a panel of locksmiths, and 'cylinder bumping' tests.
BS 10621: 2007 + A1:2009	Thief resistant dual-mode lock assembly	This standard is applicable to single-point locking systems where a key is not required for exit and the locking system incorporates two 'modes' (e.g. daytime operation and night-time operation). The standard incorporates the requirements of BS EN 1303 for cylinders and BS EN 12209 for locking hardware. It also includes manipulation tests, conducted by a panel of locksmiths, and 'cylinder bumping' tests.
BS EN 12051: 2000	Building hardware. Door and window bolts. Requirements and test methods	This standard is applicable to single-point bolts operated by levers, knobs, sliding etc. but not the use of a removable key (e.g. barrel bolts). The standard defines a number of requirements including: <ul style="list-style-type: none"> • Resistance to end and side loads. • Resistance to sawing of the bolts. • Projection of the bolt. • Other requirements such as fire and corrosion resistance. The standard defines a seven-digit classification: <ol style="list-style-type: none"> 1. Category of use - light duty (grade 1), medium duty (grade 2), heavy duty (grade 3) and extra heavy duty (grade 4) 2. Durability - 2500 cycles (grade 1), 5000 cycles (grade 2), 10000 cycles (grade 3) and 50000 cycles (grade 4) 3. Door mass. 4. Suitability for use on fire/smoke doors. 5. Safety in use - No safety (grade 0) or meets the performance requirements for operation after side loads. 6. Corrosion resistance - Five grades ranging from grade 0 (no defined resistance) to extremely corrosive environments (grade 4). 7. Security - Five grades depending on resistance to end loads up to 5000 N, resulting projection, resistance to sawing up to 5 minutes and resistance to side load up to 10000 N.
BS EN 12209:	Building hardware. Locks and latches.	This standard is applicable to mechanically-operated locks and latches and their associated locking plates (keeps). The standard defines a number of requirements:

NOT PROTECTIVELY MARKED

Standard	Title	Description
2003	Mechanically operated locks, latches and locking plates. Requirements and test methods	<ul style="list-style-type: none"> • Torque resistance of operators. • Resistance to end and side loads. • Resistance to pulling and lifting. • Resistance to drilling. • Resistance to pulling, disengaging and forcing of hooks and claw bolts. • Other requirements such as corrosion resistance and type of key and spindle operation. <p>The standard defines an eleven-digit classification. The seventh digit relates to the locksets security and drill resistance and is graded 1 (lowest) to 7 (highest).</p>
BS EN 12320: 2001	Building hardware. Padlocks and padlock fittings. Requirements and test methods	<p>This standard is applicable to padlocks and associated padlock fittings (e.g. hasps and staples). The standard defines a seven-digit classification:</p> <ol style="list-style-type: none"> 1. Category of use. 2. Durability. 3. Door mass. 4. Suitability for use on fire/smoke doors. 5. Safety in use. 6. Corrosion resistance - grade 1 (internal use) or grade 4 (external use). 7. Security - Six grades depending on resistance to the following methods of testing: <ul style="list-style-type: none"> • Resistance to torques and forces on the cylinder plug or locking mechanism. • Resistance to pulling, twisting and cutting of shackle and staple. • Resistance to drilling and sawing of body, shackle and staple. • Minimum number of effective key differs and the non-interpassing of keys with just one interval differ.
BS EN 14846: 2008	Building hardware. Locks and latches. Electromechanically operated locks and striking plates. Requirements and test methods	<p>This standard is applicable to electromechanically-operated locks and latches. The standard defines a number of requirements including:</p> <ul style="list-style-type: none"> • Security and drill resistance as per BS EN 12209. • Resistance to voltage drops, electromagnetic and electrostatic manipulation, electrostatic discharge and wire manipulation. • Corrosion and environmental resistance. <p>The standard defines a nine-digit classification. The seventh digit relates to security and drill resistance, and is graded 0 (lowest) to 7 (highest). The ninth digit relates to resistance to electrical manipulation, and is graded 0 (lowest) to 3 (highest).</p>

Standard	Title	Description
LPS 1242: Issue 2	Requirements and testing procedures for the LPCB approval and listing of cylinders for locks	<p>This standard is applicable to lock cylinders. It is similar to BS EN1303. In fact, the first eight digit classifications fully reflect those defined in BS EN1303. The remaining classifications, and the higher key-related and attack resistance classifications, are specific to LPS 1242. They were developed to address vulnerabilities that it was considered were not suitably addressed by EN 1303, in particular, relating to higher security applications. In particular, it includes:</p> <ul style="list-style-type: none"> • A security rating classification confirming the cylinders resistance to manual attacks in accordance with the classification system contained in LPS 1175. • A digit confirming whether the cylinder resists manipulation using ‘bumping’ techniques. • A digit confirming whether the key used to operate the cylinder is covered by a valid patent, thereby giving a degree of legal protection against unauthorised copying of keys.

Table 7 Guide to classification icons used in relation to European hardware standards

Attribute	Symbol	Attribute	Symbol
Category of use		Safety in use	
Closing force		Security	
Corrosion resistance		Suitability for use on fire and smoke control doorsets	
Durability		Test door mass/size/weight	
Field of door application		Type of key	
Hinge grade		Type of operation	
Hold-open force		Type of spindle	
Key identification	 _m		

Appendix C: Third party certification

Many issues can affect whether a doorset offers the performance required within the forcible entry performance standards (see page 37) once the doorset has been supplied and installed. It is therefore important to ensure that:

1. Test evidence supplied to confirm the doorset offers the required performance covers:
 - the size, construction and configuration of the doorset;
 - the hardware fitted to the doorset;
 - the method of installation.
2. The tests were independently conducted by a suitably recognised and experienced laboratory that is recognised by CPNI and, where possible, is independently accredited by a recognised accreditation body such as the UK Accreditation Service (UKAS)^{aa}.
3. The doorset's conformity with the performance requirements specified is confirmed by a third party certification body which:
 - is independent of manufacturer's or supplier's interests;
 - regularly audits the production to ensure the units produced continue to meet the required performance classifications; and
 - is, where possible, independently accredited to BS EN 45011:1998 by a recognised accreditation body such as UKAS.
4. The doorset is installed in accordance with the manufacturer's approved instructions, into openings constructed from materials identified as being compatible with the doorsets' performance and falling within the tolerances permitted. In order to ensure the quality of installation work undertaken and performance of the doorsets once installed, it is recommended to ensure those installing the doorsets are approved under recognised third party installer schemes, such as those operated for fire doorsets by BM Trada, FIRAS and LPCB, or those operated for security doorsets by third party certification bodies such as LPCB.

^{aa} UKAS accredits laboratories against the requirements contained within the international standard for management of laboratory and testing services, BS EN ISO/IEC 17025: 2005.

Appendix D: Alternative methods of lock operation

The following table lists alternative methods by which locking hardware may be operated in approximate order of their relative resistance to manipulation by intruders.

Type of hardware	Description	Side of doorset	
		External	Internal
None	No operating hardware is fitted to one face of the door leaf. No access or egress is possible from that face.	✓	✓
Key	Access / egress via a key-locking cylinder, typically with a lever handle.	✓	✓
Access control	<p>Locking systems requiring a power source to operate correctly fall within two categories:</p> <ul style="list-style-type: none"> Those requiring power to maintain the doorset in the 'locked' condition, e.g. electromagnetic locking systems where the door is held closed by an electromagnet. Those requiring power to 'unlock' the doorset, e.g. solenoid-operated locking systems where a solenoid retracts when power is applied to release the deadlock. <p>If power source is removed (e.g. a power cut or an attacker manipulating the wiring), normal operation of the doorset may be impeded.</p> <p>Fail safe access control locks</p> <p>Those in the first category will 'fail safe', i.e. the doorset will unlock and be made safe such that people can exit in an emergency. However, this also means unauthorised people may easily be able to gain entry.</p> <p>Such locks are vulnerable to disengaging automatically if the power to the lock is interrupted or falls below the level required to create to maintain the lock in the secured state. 'Fail safe' locking systems are therefore not recommended for use on security doorsets.</p>	✓	✓
	<p>Fail secure access control locks</p> <p>These devices generally incorporate a sprung solenoid or a motor that requires power to be applied to retract the bolt, disengaging the deadlocking mechanism. This is achieved by entering the correct code into an access control system. This allows power to flow to the solenoid/motor located within the lock. It is important to ensure:</p> <ul style="list-style-type: none"> Means are provided to operate the locking system from within the secured area without the need for a key or other token. This is to help ensure safe egress in an emergency. <p>The wires feeding the power to the solenoid are protected to prevent unauthorised access being gained to apply power to the locking mechanism to operate it.</p>		
Thumbturn	The deadlock is retracted by turning the thumbturn, allowing the bolts to retract using a lever handle or other such device.		✓
Emergency	Egress is achieved by turning a lever handle or depressing a push plate or push		✓

NOT PROTECTIVELY MARKED

Type of hardware	Description	Side of doorset	
		External	Internal
exit device	pad in the direction of exit.		
Panic exit device	Egress is achieved by depressing a full width push plate or bar in the direction of exit.		✓

Appendix E: Glossary

In addition to the descriptions contained within this glossary, consideration should be given to reading the following national and international standards:

BS EN 12519:2004 Windows and pedestrian doors. Terminology. BSI, March 2004.

BS EN 12433-1:2000 Industrial, commercial, and garage doors and gates. Terminology. Types of doors. BSI, August 2000.

BS EN 12433-2:2000 Industrial, commercial, and garage doors and gates. Terminology. Parts of doors. BSI, August 2000.

Term	Description
Active leaf	The first leaf to open on a double doorset with leaves incorporated rebated meeting stiles.
Astragal	Bar or moulding that is usually attached to the leading edge of the attack face of the (active) leaf on outward opening single or double leaf doorsets. Its purpose is to inhibit access between the leading edge of the leaf and frame (single leaf doorsets) or between the two leaves (double leaf doorsets). It is typically used when the leading edge of the leaf(s) are not rebated. An astragal may also be fitted to: <ul style="list-style-type: none"> - The leading edge of the protected face of the (active) leaf on inward opening single or double leaf doorsets. - The leading edge of the attack face of the passive leaf on inward opening double leaf doorsets. - The leading edge of the protected face of the passive leaf on outward opening double leaf doorsets.
Boltwork	Combination of the lock bolts and the mechanism (sometimes referred to as the central boltwork mechanism) that operates the lock bolts.
Butt hinge (loose pin)	Hinge with a 'loose' removable central pin within the knuckle formed between the two flaps (leaves) that attach the hinge to the door frame and leaf.
Butt hinge (lift-off)	Butt hinge with central pin fixed to one flap that can be lifted away from the other.
Butt hinge (security)	Hinge with a central pin secured within the knuckle to prevent its removal (e.g. using welds or grub screws)
Header	Also referred to as the 'head'. This is the section of a door frame running across the top of the doorway, linking the two vertical frame members (jambs).
Jamb	The vertical sections of a door frame. Two types of jamb are commonly referred to: <p>Hinge jamb. This is the jamb to which the hinge(s) that support the door leaf is/are attached. Only one hinge jamb is present on single leaf doorsets, while two hinge jambs are located on double leaf doorsets.</p> <p>Strike jamb / locking jamb. This is the jamb that incorporates the lock bolt / latch keeps. This jamb is only present on single leaf doorsets.</p>
Latch	Lock bolt that is designed to retract automatically when it strikes a strike plate and then engage automatically within the bolt keep located within the strike plate.

NOT PROTECTIVELY MARKED

Term	Description
Leading edge	The edge of the door leaf furthest from the hinged side. This is the edge of the leaf to which the lock is typically fitted to.
Maglock	Maglocks comprise an electromagnet and an armature plate (see Figure 10). The electromagnet is attached to the frame on the protected side of the doorset, while the armature plate is usually attached to the protected side of the door leaf via a bracket. Power is fed to the electromagnetic in order to secure the door in the closed position. This creates a magnetic field which attracts the armature plate.
Meeting stile	The edges of the leaves on double leaf doorsets that meet when both leaves are closed. These edges are otherwise known as the leading edges.
Opaque infill panel	A panel fitted within the door leaf, or adjacent framework, which cannot be seen through. These most commonly form decorative panels on domestic or ornate doorsets.
Passive leaf	The second leaf to open on a double doorset with leaves incorporated rebated meeting stiles.
Piano hinge	Extended version of a butt hinge, generally running along the full height of the door leaf. This type of hinge is otherwise known as a 'continuous hinge'
Pivot hinge	Formed from pin located into roller pin assembly and housed above/ below the trailing edge of the leaf.
Projecting hinge	Projecting arms joined by a mechanical fastener or lift-off pin.
Rebated frame	The frame of the doorset either has a rectangular section routed out of the frame elements (timber leafed doorsets) to form an 'L-shaped' cross-section or is formed into an 'L' shape, 'P' shape or 'T' shape (steel, aluminium and PVCu frames). The rebate is designed to support the edges of the door leaf when it is in the closed direction.
Rebated meeting stile	The leaf edges are profiled so that the edges of the two leaves overlap each other (see Figure 3). This helps to prevent the gap between the leaves being penetrated with tools during attacks.
Shear locks	Shear locks use electromagnetism to engage grooves or pins within the armature plate or keeps in the electromagnet's housing. As their name suggests, these act in shear because their plane of engagement is perpendicular to that of the door's opening direction. See Figure 11.
Strike plate	Plate designed for a latch to strike as the door closes, causing the latch to retract and then engage into the keep located within the strike plate.
T-bar hinge	Hinge with two flaps, one of which is long and tapered and the other narrow and vertical.
Threshold	The floor directly below the door leaf. This may either be: Flat: this is typically the case with internal doorsets on busy corridors and emergency exit routes, and is to avoid trip hazards. Stepped: this may be to provide a seal to improve the doorsets': weathertightness (external doorsets); resistance to manual attack; resistance to passage of fire and smoke; thermal performance, and resistance to the passage of noise.